

radio control MODEL CARS

ISSUE 13

Price 50p. \$1.50 (US) DM3.50

Fr. F6 Gir. 3.50 SwFr. 3.00



MODEL CAR



MAIL ORDER SALES: Ted's new Catalogue 56-pages, 134 photo illustrations covers a vast range of products. Send 50p for it now (your money back on the first order).

"PBS"

In response to numerous enquiries we are pleased to announce that we are co-operating with World Champion Phil Booth to bring on the market "Phil Booth Special" parts.

Phil who is co-designer of the famous PB International is always striving to improve handling, speed, etc., and these modifications ranging from a complete ready-to-run to an improved servo-saver mount are now available to order. If you are interested in a tuned engine, a tuned chassis, or any other genuine "PBS" product, give Ted a ring.

We carry the following MARQUES, Kits and Spares: Associated, Delta, Marker, Thorp, PB International, SG, Serpent, plus 1/12 ELECTRICS Associated, Bo-Link, Mardave, MRP. Lexan and ABS bodies in 1/8 and 1/12. RADIOS (two channel only) Futaba Twin-Stick, Futaba Steering Wheel, Digiace, Sanwa, MacGregor, Trigger Conversion Kit. Accessories include AMPS Differential, PB Diff, Serpent Disc Brakes, Perry Pumper Carbs. TYRES 1/8 and 1/12 from all major manufacturers: Associated, UFRA Thorp, Delta, PB, etc., ENGINES OPS, K&B, STX21, Veco.

Mail Order Only Address (no stock held here) European Export No Problem. Trade Enquiries Welcome

80 PEPYS ROAD, LONDON SE14 01-639 5080

R/C Ted Longshaw for Service & Experience



**8 YEARS INTERNATIONAL RACING
EXPERIENCE IS AVAILABLE TO HELP YOU!**



radio control MODEL CARS

Published by L-D EDITORIAL — TECHNICAL SERVICES LTD., P.O. Box 30, HEMEL HEMPSTEAD, HERTS. HP1 1NL. NOVEMBER 1979.

Editor: "Dickie"
Laidlaw-Dickson

A CASE FOR STEWARDS

DURING the current season I have attended three international meetings in Europe, two main meetings in this country and several of lesser importance. Organisation has ranged from excellent to ghastly! A glance at the EFRA Rules for 1979 gives very little help in the conduct of meetings — far more space is devoted to action in the case of rain than to anything else. Just in passing at least two major event organisers had never seen the rain rules! It is very sad that some meetings are interrupted by long and fruitless discussion by an overlarge group on protests — to such an extent even that at Nuremberg it was necessary to re-run a disputed race on the following morning at an early hour when overnight rain produced entirely different racing conditions. In the same vein it was possible for BRCA Secretary, presumably acting as BRCA representative, to stop a race at the Tibshelf Nationals meeting.

To what extent these actions were warranted is not my present point. Both these cases provoked a degree of resentment from drivers — some drivers I must add — in that the traditional "justice must not only be done but be seen to be done," did not apply. I know that it has always been the policy for the local Race Director to have unhampered freedom in organisation and an overriding say if matters come to a deadlock. I would like to advocate the appointment of BRCA stewards with appropriate authority to decide protests without delay on the spot and for such stewards to be the normal practice at all EFRA meetings everywhere. Provided clear rules are set out for their benefit this should reduce time wasting talk, to quote a former colleague's wall motto: "When all is said and done a great more is said than done."

Another aspect of international events has been the absence of official help, or even official presence, of national governing body members at these meetings. I refer specifically to World Championships at Geneva, admirably run by Jean-Claude Rumbeli, but without any visible help of the Swiss National Club or Association, or the supporting presence of its leading officials. Much the same was the case at Nuremberg... local freedom is all very well but a little help...

The newly formed world organisation offers a splendid opportunity to iron out weaknesses such as this. Fullsize racing is equally sometimes in trouble on regulations but it is noteworthy that the Jockey Club with several hundred years of experience has got it all so buttoned up that even the highest in the land tremble before the authority of its Stewards!

THE MEN AT THE TOP . . .

I have written before about our contest 'elite' the front runners most likely to win races; and how often they do! Is the time ripe for the establishment of a, shall we call it, 'professional' class? This would embrace naturally the genuine manufacturers (not the little man with a few garage-built goodies) the genuine model shop/manufacturers and the recognised highly sponsored teams that these groups bring together. There would be bound to be borderline cases of 'are you arn't you?' but not beyond resolving amicably.

With such a clearly defined top group who would probably number at the most some two dozen in each leading country, down to less or none in smaller EFRA nations, there could no longer be the sometimes heard sour comment: 'Not going there: we all know who's going to win!' To this top unit would be added the

**CONTENTS: EDITORIAL . . 3 : CLUB & TRACK REVIEW . . 5
: CMABRIA SAAB ELECTRIC . . 8 : BELGIAN GRAND PRIX
. . 12 : BRITISH NATIONALS . . 17 : ROBERTS WINE STOX
FIESTA . . 22 : BP-HADLEY CITY GRAND PRIX . . 26 : EURO
CHAMPS . . 28 : WORLD CHAMPS PT 2 . . 34 : WHAT
ABOUT A WHEELIE? . . 39 : PAINTING MODEL CAR
BODIES PT 2 . . 40 : PB 9 WORLD CHAMPION . . 46 : CORGI
GRAND PRIX . . 48 : DONINGTON PARK . . 50 : SHOPPING
AROUND . . 54 : FRENCH 1/12 ELECTRIC CHAMPS . . 57**

13



Young Entry! Jeremy (11) and Jonathan Taylor (13) youngest drivers at British Nats. Jonathan already as a 25% handicap. Red Rose Racing with local Lancia sponsorship relies on PB equipment plus Greeno advice with Wrexham's acting secretary Gordon Taylor as a Dad/Mechanic/Manager.

high handicap drivers, say 25% and above which might well make up a pleasant entry for an Open Meeting of around eighty, or perhaps down to a strong fifty. This would give the handicap drivers the welcome feeling of having arrived amongst the big boys, ensure that any budding talent was there to be encouraged and yet allow for longer qualifying heats and a better time all round. Under such circumstances it might be possible to follow the American system which I have long admired of running "A Main" "B Main" and so on according to time allotted.

This leaves the lower handicap drivers free to attend a separate Low Handicap Nationals where the up-and-coming but still coming drivers would race against their peers with more satisfaction. Such meetings run during the past season have been very well received, even in bad weather conditions.

A final comment on top drivers. This professional approach is already invading the 1/12th electric scene with works teams scooping the prizes. Certainly they claim to running standard cars with standard motors, but like the animals in *Animal Farm* who were all equal, but some more equal than others, motors tend to follow the same pattern. On test before distribution they all produce power within an acceptable range: those failing to reach it go on the reject pile, those exceeding the norm go on another pile, perhaps with a code mark dabbed somewhere. It is not beyond the bounds of possibility that such motors grace works entries. One way to cure this (if it is felt that works teams are

not yet thick enough on the ground to justify a separate class) would be to have motors issued to drivers at the meeting, charging them the additional cost in their entry fees at best bulk purchase rate. After all fuel is issued to model aircraft flyers . . . but we must not get on to that other controversial topic to nitro or not to nitro. .

CITIZEN BANDWAGON . .

An indignant model wholesaler has drawn my attention to a Summer Special (One-Shot) from *Hobby Electronics* entitled *Citizens Band*. What should be the r/c modellers' attitude to CB? It could well be a contributory cause to much of the radio interference suffered this season and in the U.K. is strictly illegal and gear subject to confiscation. However, this does not alter the fact that already twentyfour countries have legalised it, or are preparing so to do, nearly all on the 27MHz band. This Summer Special puts a very reasoned viewpoint speaking as radio buffs, with a modellers' viewpoint expressed by the Chairman of the S.M.A.E., who suffer the most potentially dangerous and costly interference from CB's illegal use. With international meetings, I believe, scheduled to consider further re-distribution of bands in the near future, surely it is the time to press for further alternative wavebands exclusively for model use which are not so liable to outside interference. CB will come, however little we may like it, r/c model interests should have their practical alternative at the same time. Readers views will be welcome.

CLUB & TRACK REVIEW

Euro Champs 1980

THIS year's racing season is over and points are now being accumulated to qualify for next year's Euro Champs scheduled to take place in Sweden. Already the Swedish organisers are making ready for the event. I have been given an aerial shot of the circuit and presented with a large T-shirt advertising the event: "Vast 8-Ring Euro R/C Car Champs 9-10 Aug Gothenburg Sweden". How to get there (start saving now?) will loom large. I believe the sea crossing which takes a day and a night to Gothenburg is pricey, but with a full load for car there are still some concessions on the caravan . . . it is a lovely trip anyway if you like the sea. Another way that I rather fancy is to cross over shortest route from Dover and turn left motoring up through Denmark to cross by the ferry at Malmo to Sweden. This could make a very pleasant combined race/holiday occasion, enjoying the little bit of German sands on the Baltic near Lubeck. The rich can always fly. More later.

London R/C Car Club

Secretary Bob Rosser tells me that alas Leyton Raceway is no more! A short and not very eventful life for what promised to be an exciting venue with possibilities of re-opening the original restaurant and other facilities. I gather the idea is to build on what is of course a prime site. However, with these things you never know — there could even be a reprieve. A pity perhaps that the Bovingdon airfield

site where planning permission has actually been granted was never pursued further. Certainly the flying club have got rights on part of the site but surely negotiation is not impossible. (Forgive my vested interest living three miles from the airfield!)

The Sussex Adders

(Arun District Electric Racing Society)
Secretary: Mrs. A. M. Green
30 Charlton Street
Steyping, Sussex

Chairman A Churly writes that the club has been operating since February 79 with weekly meeting and is looking for new members to expand its target figure to thirty members from the current twenty by December. Monthly and half-yearly championships are run, and the occasional newsletter is published by the chairman. Members also race regularly at the Solent Car Club based at Portsmouth, and the Sussex Club at Eastbourne has also been visited. Meetings are held each Friday at Eastergate Parish Hall at 20.00 hrs and racing continues until 23.00 hrs at a cost of 50p a night to members (£2 p.a. sub) and 75p to non-members. Silicon is needed for the dusty and not too smooth floor. Most makes of car are represented but scratchbuilt cars (hurray! Ed.) tend to dominate. Would-be members should get in touch with membership sec. as above.

Next year's Euro Circuit at Gothenburg, Sweden . . . see you there!

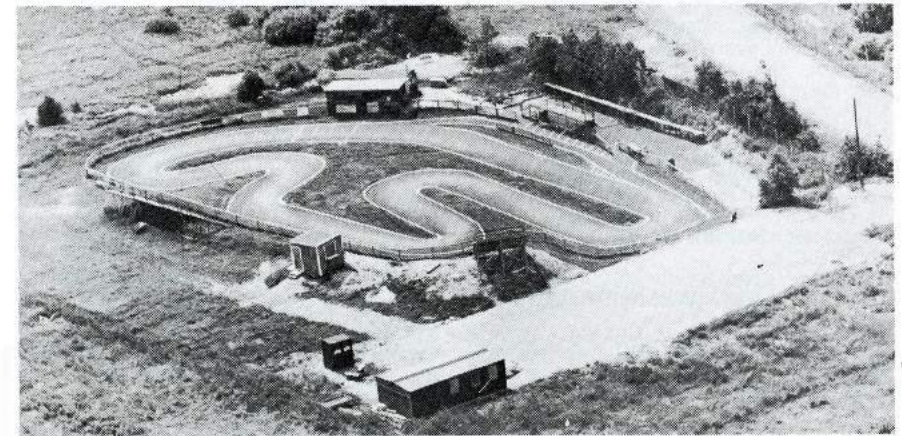

Wrexham Model Car Club
Chairman & Acting Secretary:
Gordon Taylor
"Henley"
Rookery Drive
Tattenhall, Cheshire

With a very pleasant woodland circuit it is not surprising that the club is still growing in membership and successfully running their own club championship. A date will be sought for the Welsh Grand Prix in 1980 by which time the new team will be experienced enough to cope with a national fixture. A five round "Driver of the Year" competition has just been completed. Suspense was maintained until the last round when Jonathan Taylor clinched the title for the second year running by one point from Charlie Williams. Mel Hughes was third. Formula 1 Championship was run on September 3rd with the 1978 champion 14-year old David Tuck holding the lead until his differential cried 'enough'. Fred Livesey and Charlie Williams fought it out to the last seconds when Fred galloped to the flag first. A feature suggestion from secretary is well worth following up. "What about a series of Driver Profiles in the mag? The who, the what and the when!" Another alternative would be: "My last two months driving — how I did it!" I must corner some of our shy (?) stars with a tape recorder and beat it out of them.

Cleveland R/C M.C.C.

Secretary: K. Rigby,
1 Topcliffe Road
Thornaby, Cleveland.

The club has been going for about a year with a membership of over fifty of whom some twenty or so are active. It is based in the Middlesbrough area with interests in both 1/8th scale i.c. racing and 1/12th electric. The larger scale meets every Sunday afternoon with electrics every Friday evening during school terms. Contact the secretary as above for membership details or telephone Chairman Dennis Trowbridge (Stockton 583244). Dennis it will be noted has been making a foray or two notably at the handicap meeting at Lilford earlier in the year, and more recently at the Nationals at Tibshelf with notable success.

Wickford Radio Electric Car Klub (W.R.E.C.K.)

Secretary: Colin Smith
79a. Mill Avenue (Wickford 63702)
Wickford, Essex

Another lovely acronym — though secretary hastens to point out that this does not reflect driving standard: Situated in Wickford home of E. Keil and Co who distribute the greatly sought OS 21

engines it should not be hard for the club to build up its membership which is what they would like. Meetings take place on alternate Friday evenings on the local car park and indoors during the winter.

Bournemouth Radio Auto Club

Secretary: Bob Errington
19 Archdale Close
Bournemouth
(Bournemouth 524524)

Bob reminds me that the club meets most Sunday afternoons on the Tubary Park track, scene of some heroic tussles in recent months. There is a regular club handicap in operation with frequent friendly club meetings, and a 1/12th scale electric section is now in operation. Membership stands around 50, though sec. always happy to hear from prospective members.

Swindon Electric Throttle Benders Club

Secretary: Jan Korda
Swindon Model Centre
(Tel: Swindon 26878)
2 Theatre Sq.,
Swindon Wilts

The club is going from strength to strength reports sec. Jan Korda. Owing to demand the electric section continues to meet throughout holiday periods Thursdays evenings. The i.c. cars are now racing at Chisleton Camp with a marked track on smooth tarmac with rostrum etc and superb facilities. This section now has twenty members — new ones always welcome. Clubman Fred Martin recently won the Wrexham F/1 Open event so standard is pretty high. Note: As circuit is on M.O.D. land passes are required to be allowed in. These can be obtained from the Swindon Model Centre.

Tameside Radio Model Car Club

Secretary: Roy Johnson
54 Urwick Road,
(Tel: 061 430 4144)
Romiley, Stockport
Cheshire SK6 3JP

Please note new secretary as above. Prospective members contact Roy or Chairman Ron Aspinall (Tel 061 366 9054). The club has the use of the Finefare Supermarket car park on Sundays from midday and on Monday evenings. During the racing season most of the more active members visit various BRCA open meetings, but a winter series of meetings is to be held locally. An electric section has just been formed and local T.A. drill hall has been obtained for meetings every Wednesday evening 6-10 pm. This should provide a 30 to 40 yard straight and make for an excellent circuit.

(Continued on page 56)



PHIL GREENO

MODELS LIMITED

9 Village Way East, Rayners Lane, Harrow, Middx. Tel. 01-8667770

"THE WINNING COMBINATION"

A limited number of Phil Greeno cars are now available ready made and ready to race less radio and engine. Each car includes: G.R.P. chassis, A.M.P.S. differential unit, Delta steering, flip top tank, roll bar, brake adjuster, racing clutch, engine mounts, aerial, alum. body post, wheel/tyres, silencer, all linkages, Lexan body of your choice **£266.25** (or made to order).



Veco/McCoy parts always in stock

ACCESS! BARCLAYCARD! HOBBYCARD! H.P. TERMS PLUS FAST MAIL ORDER

SPECIAL ITEMS

- *NEW Tuned Racing Silencer **£16.95**
- *NEW Lexan Paint 8 colours **£1.00**
- *NEW Metallics 5 colours **£1.10**
- *NEW Fluorescent 5 colours **£1.00**
- *NEW GRP NARROW Chassis **£8.50**
- *NEW GRP Standard Chassis **£9.05**
- *NEW GRP WIDE Radio Plate **£6.95**
- GRP Standard Plate **£3.14**
- Brake Adjuster **£4.20**
- Roll Bar **£2.92**
- Alum. Body Post **£1.59**
- Comp. Clutch Nut (P.B.) **£2.75**
- Flip Top Tank **£14.37**
- Pumper 61 Carb. **£9.60**
- Perry Pumper 61 carb. (turned to 12mm) **£10.60**
- S.G. Air Filter **£2.07**
- P.B. Air Filter **£2.92**
- Delta Fuel Filters **£1.59**
- Delta Output Arm **£1.00**
- Assoc. Fliptop Lid **£3.99**
- Field Charger **£8.46**
- Glowpack **£16.98**
- Machined Engine Blocks **pr. £2.07**
- Machined Rear Power Pod **£8.89**
- Machined aluminium Front Beam Mk 2, wider front track **£14.85**
- NEW Ballraced Disc Brake complete with fibre disc machined steel shoes **£15.92**
- NEW Ballraced Disc Brake complete with fibre disc machined steel shoes, assembly with Brake Adjuster **£19.11**
- Ditto DOUBLE ballraced **£20.18**
- A.M.P.S. Differential Unit with bearing blocks and disc unit to fit P.B. International **£57.45**
- Racing Special **£60.65**
- NEW Mini Diffs to fit PB Int. RC200, Serpent from **£35.67**
- *NEW 1/12 Diffs in stock 'PB Diff. **£36.21**

R.C. CARS

- P.B. International No. 9 **£127.26**
- P.B. International No. 8 **£95.31**
- P.B. International No. 7 **£70.39**
- P.B. International No. 6 **£79.87**
- P.B. Expert Comp **£65.36**
- S.G. Comp **£71.05**
- S.G. Futura III **£76.68**
- Associated RC200 **£127.74**
- Associated RC1 **£85.14**
- Serpent III **£80.71**
- Delta 780 Super J **£111.82**
- Mardave Formula **£25.29**
- Mardave Saloon **£25.29**
- Mardave Stockcar **£25.29**
- Ke'jon Stock Car **£34.75**

PLUS A large stock of R.C. car spares always in stock including P.B. Associated, S.G., etc.

- Jerobee r/c electric **£59.58**
- Lectricar with prop. speed control **£47.78**

All prices correct at time of going to press but subject to alteration.

ENGINES

- O.P.S. 21 Car **£52.13**
- ST X21 Car **£51.40**
- K & B 21 R/C **£50.58**
- Veco 19 R/C **£29.23**
- New Veco 21 R/C **£31.89**
- Irvine 20 R/C **£38.28**
- ST X21 RE inc. manifold silencer, airfilter, heatsink **£64.96**
- ST X21 Re inc. heatsink and airfilter **£60.70**
- *NEW HB 21 PDP Car Engine **£40.89**

Plus parts available separately

*NEW 1/12 Diffs in stock

Also large stock of BO-LINK, JOMAC, JEROBEE, ELECTRO CRAFT 1/12th ELECTRIC CAR KITS AND ACCESSORIES

*NEW Full Range of TAMIYA KITS

REWORKED MOTORS

- Inc. Pumper Carb. **£75.00**
- Q.P.S. 21 **£75.00**
- ST.X21 **£75.00**
- K & B 21 ("McCoy-ed") **£75.00**

specialists in SKYLEADER FUTABA SANWA MacGREGOR

Opening hours: Mon., Tues., Thurs. 9.30-6.00 Fri., Sat. 9-7.00. Closed all day Wed.

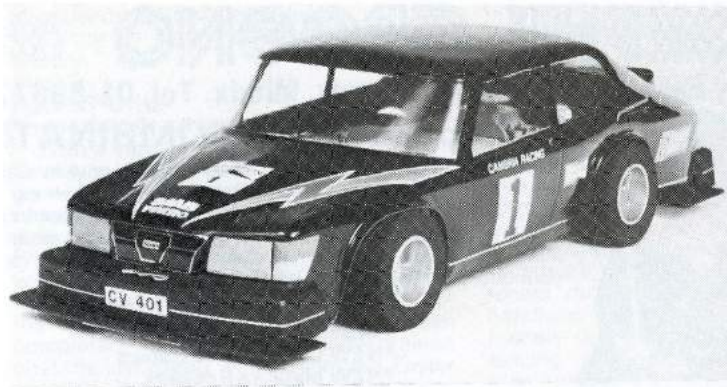

**FIRST
1/12
ELECTRIC
FWD
CAR**

CAMBRIA SAAB

AS A practising enthusiast for front wheel drive (owner and ex-owner driver of two Minis, Renault TL5 and Volkswagen Polo) I was eager to see how the promised Cambria SAAB tackled the problem in miniature. Happily I was lucky enough to receive one of the first two hundred cars that went out and got down right away to building my kit. An 18-page A/4 (11¼ x 8¼ins) size instruction booklet provides a well documented path to a satisfactory model, and there everything is covered in a sensible logical sequence.

The kit comes in a stout box with the various stage-by-stage parts in separate lettered packs resting in two long trays each side of the bodyshell included. Apart from jumping the gun and sticking the tyres on the hubs as a first step, I followed the book starting with Pack A and working through steadily. First stage gets the motor mount parts installed in the front of the alloy chassis plate. (Perhaps later on Cambria will offer a special fibreglass chassis plate as an alternative — I was tempted to make one up but refrained).

Pack B introduces the first part of the exciting front end drive and steering in the shape front axle shaft. This is a double ball-ended shaft and I slipped it on the lathe to polish it sweet as a nut with a slip of emery paper. Not an essential job but it all helps to a trouble free unit. Drive gear is attached at this stage though not locked in place. Then come the Pack C parts with the left and right hand wheel hubs and bushes and the steel stub axles and stub axle collars. These parts are bits that really matter.

Some of the early kits went out with their front hub oilite bushes flush with inner face of the hub when they must be flush with outer face. Do not clout them with a hammer to get this right but press them back in a vice. You will need a large nut or piece of metal with a hole in it big enough to take the bush clear and another bit of metal or wood that will clear the steering arms. Close the vice firmly and the bush will go back to its right place. (Cambria say tap them back — I still think they ought to be pressed!) This will ensure that if raced your car will not be disqualified on scrutiny for being over-wide — if not racing it does not matter. You may still be very fractionally over-size so check overall width at a later stage when it may be desirable to rub down wheel and hub to reduce by about 1/32 or less each side. Again a little emery paper to polish up the stub axles pays off.

Now comes the time with Pack D that it really begins to look like a FWD car! Front suspension units are screwed in place with the self tappers supplied and the hubs put in place with the steel kingpins. The two little drive pins that go through the axle ball ends move freely in their holes, so be careful not to mislay them at this stage. Once the hubs are in place they are held there safely.

Quiet interval after the excitement: Pack E sets up the rear end — perfectly simple operation Pack F involves fitting the battery tray and locating the nicads in place. See that the right hand (looking from the rear) pack has its red lead facing backwards otherwise you will have to

rearrange the wiring diagram later. Join up with the block connector supplied. Two cable ties (battery straps) are provided to retain the three-cell packs. They will anchor even more securely if you slip a short length of servo tape under each side. Then fit the ties, draw up tight and cut off surplus. A tip from the designers here: Weight distribution is an important factor in FWD cars so drill a couple of holes ¼in back from the holes already on the chassis plate to enable the whole battery tray to be slid backwards if any further trim suits your style of driving. You may have to relocate the charging lead connector at the same time (Pack K).

Back to the front again with Pack G. Again a simple process of fitting the motor and pinion gear. Motor has a certain amount of swing. Do not fit too tightly (cigarette paper clearance is about right).

Steering set-up is quite cunning. Servo saver unit fits directly on to the radio servo output disc. Try your servo for size — I noted that the larger Futaba servo will just not go in the space between battery tray and steering complex: smaller FD16M fits. You will need a clockwise servo here — the red one with Futaba, or marked with a C or a K. (Anti-clocks are black) Pack I contains the various steering rods, end connectors to set up the steering. I do not really like servo tape as a fixer though it could be used. I used it only to hold my servo in place for preliminary adjustment and then drilled holes to take a more rigid mount from the junk-box (I never know what becomes of the mounts that come with some servos!) Now you really have the front wheel drive unit able to show its paces. I could not resist fitting the wheels at this stage (although it does not come on until Pack L).

Printed circuit board for speed control and the resistors are assembled next. The

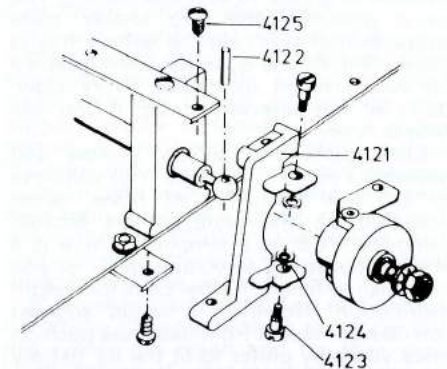
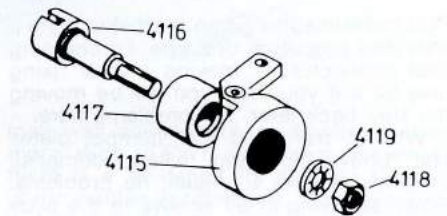
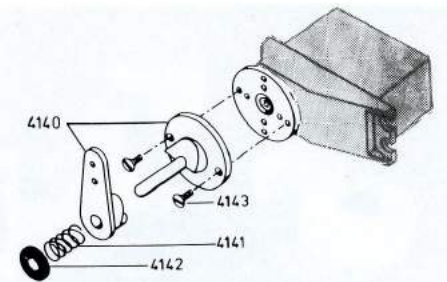

Heading: Completed works car in black with flash and clear screen and side windows.

Above: Illustrations from Instruction Manual — a very comprehensive production.

Right: Car ready to go. Control panel can be moved rearwards to provide room for a driver.

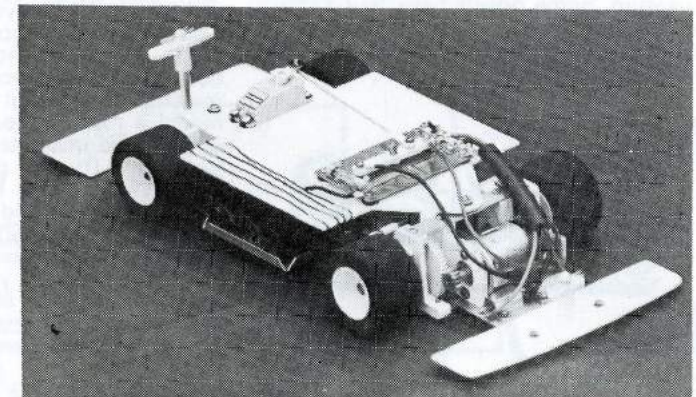

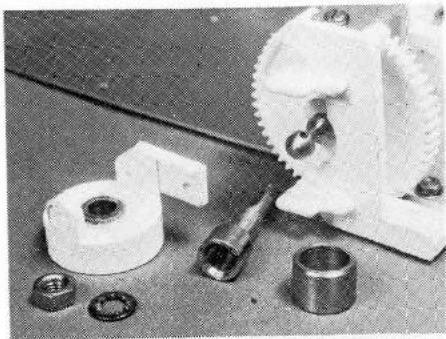

I found that my shaker plate did not line up with the predrilled holes on the rear axle hangers intended to take the screws. They also had a little ridge on them that seemed to serve no useful purpose and was not mentioned in the instruction booklet. New screw placement is not so strong so perhaps it would have been better to move the holes forward a trifle to line up. A case of wise after the event!

Final stage before you can get the chassis operative is to follow the excellent wiring up diagram. Some leads can be shortened to avoid loose leads here and there. A sleeve is provided to neaten the control/resistance assembly.

PCB is destined to go on the shaker plate a little later so put on one side. Fit charging lead connector — making a new fixing hole for it if you think you will be moving the tray back later. No problems here.

Wheels, front and rear bumper plates and body mounting pillars comprise contents of Pack L. Again, no problems. When screwing in ST screws to the alloy rear body post put it in the vice and thread them in slowly and deliberately with a little vaseline or grease to ease the cutting. The same goes for the two shaker plate supports that also hold the battery tray in place. The alloy is quite hard and needs a fair bit of effort to thread. Work slow, don't let the screwdriver slip if you can help it. Very ouch.

Shakerplate and sundry screws and grommets come in Pack M. You will have to drill out a number of holes, some indicated on the plate, others located using the PCB as a template. There is a hole for the speed servo already — or you may wish to have it further back for weight distribution. However, I would suggest you do not move it from designed position since you may prefer to fit the Rx battery behind the rear axle as a weight trimming measure. Some drivers have found this a useful step. However, you may well be tapping the nicads for Rx power when this would not arise.

There remains the bodyshell to prepare. A stout ABS Saab body comes with the kit. Excess material is cut off in the usual manner: I use large scissors for the first cut, then turn up with straight and curved small scissors — nail scissors come in useful. Leave some of the wheel arch when trimming up. Fit to chassis, enlarge popped holes for the body mounts and smooth up edges neatly with glass paper.

If you just want a fun car then follow advice and paint the windows white or silver, or what you wish. For competition use rules require that windows are cut out and possess a transparent windshield; side and rear windows must be clear or open (Rule IX (p)(q) General Specification). Before cutting them out make up a paper template of windscreen shape and side and rear windows if you intend to glaze them. Allow a little extra all round for sticking them in place. Drill a few starter holes in the parts you are going to cut out and insert scissor point to get cutting. Do not try to get to the very edge with scissors or knife, leave this for a final trim up with glasspaper wrapped round a flat or curved surface according to need.

ABS can be sprayed with car touch-up paint or any of the special paints in a wide range of colours now available for car bodies. Black is a recommended colour to match prototype but I do not like it for a model it makes it look smaller than ever and can be unsighted in a dim hall at a distance. Try a good bright colour combination. Light blue and yellow are Swedish colours and make a good visible job. Clear plastic sheet windscreen and glass go on last. The ubiquitous Evo-stik will do the work for you. Coat the parts of screen that will be adhering and also the inside of the body where the panels will go. Allow to dry then place firmly in place taking care to get location right first time — that is so there will be no

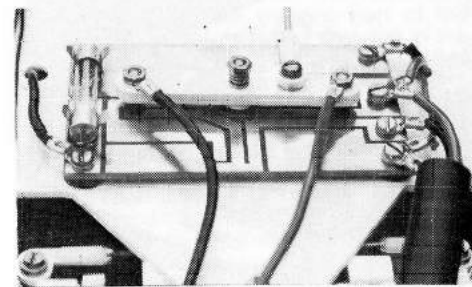

FWD Components.

Control panel detail.

Front end assembled; servo placed temporarily in position.

Right: Circuit diagram.

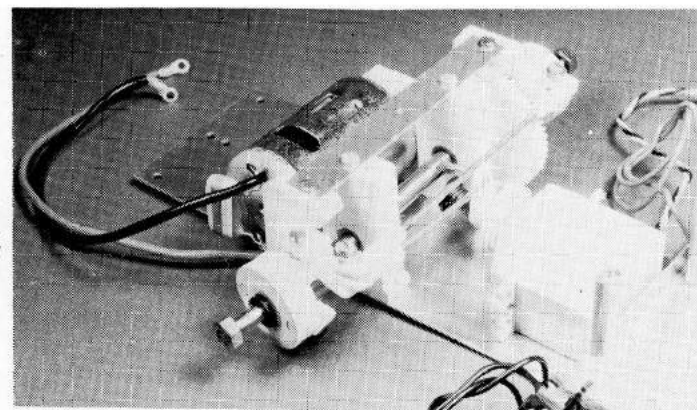

shifting about adjusting. I have a car (Ford Escort — early Mardave) whose windows have stayed put now nearly two years.

Now comes the moment of truth: running. Connect up leads and charge up the ni-cads. Since a FWD car involves a great deal more potential friction loss that a more normal layout I suggest that two or three charges of the batteries running free supported from the ground will not come amiss. This should get the universals well bedded in — remembering to give them a little touch of grease (not oil) before beginning. Other friction points, wheel bearings etc can have a little, not too much, oil. I use one of those Peco Electrolube oil-pens.

I have not said anything much about Rx and battery. There is far more room for manoeuvre with this car than usual, and these fairly heavy items can be adjusted to get balance right. Since the drive is at the front then balance should start at about 60/40% with front the heavier end. This

may well adjust back to 55/45 or even more. With all FWD cars (large and small) there is a tendency for the tail to wag under sudden acceleration. Theoretically it is bad practice to cure this by adding weight or by putting weight outside the wheelbase but sometimes it will effect a cure when nothing else does.

In any event you should find your Cambria Saab much more tractable than any other without the aid of siliconed tyres. This may still be desirable on very slippery indoor surfaces but to a lesser degree. A last thought maybe: do not be disappointed if you do not start winning races straight away. Rear wheel drive cars have been going for a number of years and this is the first FWD on the market: just give yourself a little time to learn its special qualities and the we shall see.

Meanwhile congratulations to Cambria for having the enterprise to put a car like this within our reach and for their very kindly pricing of what must have been an expensive job to tool up.

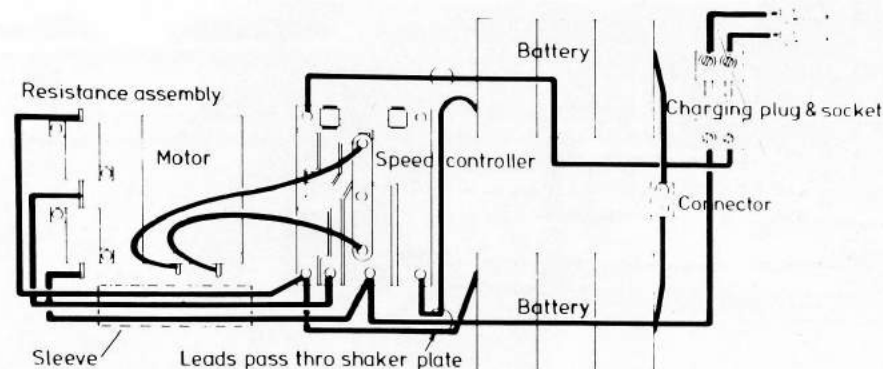

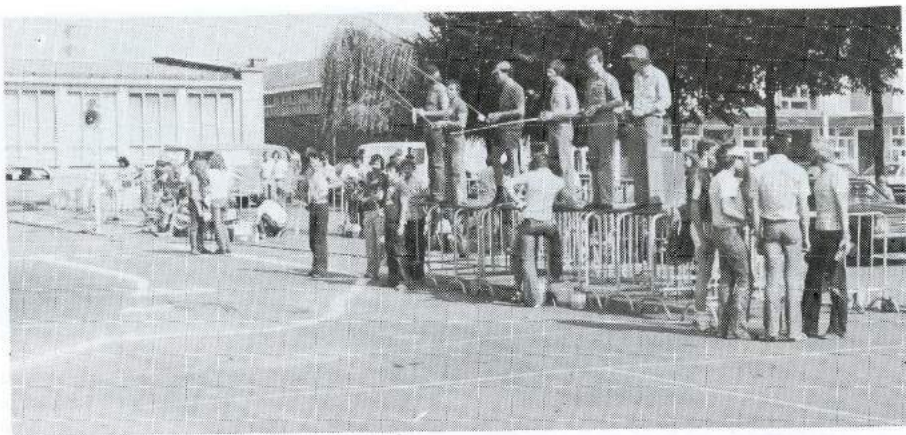

BELGIAN GRAND PRIX

REPORT BY STEVE WHITE

THE Belgian Grand Prix took place on September 1st and 2nd on a car park circuit near the town centre of Halle, about fifteen miles from Brussels. The entry included five British drivers, Phil Greeno, Malcolm and Phil Draycott, Steve White and Ted Longshaw. Practice started for the Formula event about 11 am on the Saturday morning, allowing some two to three hours before the main qualifying heats began. Surface was very bumpy, traction was almost non-existent, soft tyres were necessary, a combination of factors which made high speed driving very difficult.

After the usual three rounds of heats three drivers had made 15 lap times : Phil Greeno, Steve White and Peter Bervoets.

Fourth fastest and claiming the last straight through drive was Denny Tassaux of Belgium. Ted Longshaw was the unlucky fifth fastest. Malcolm Draycott easily qualified for the semi-final, as did his brother Phil, driving abroad for the first time. Other semi-finalists included Frank Cromberge and Ronnie Ton from the Dutch Serpent Team, Goosemans and Etienne from Belgium.

Ted Longshaw won the first 20-minute semi-final easily. Malcolm Draycott also went into the final via the second semi. His brother Phil was plagued with engine trouble which ruined his chances. Frank Cromberge and Etienne also qualified. A notable driver who did not was Ron Ton who was driving with a steering wheel Tx

Above and below: The two aspects of the circuit dry and wet — with rather more of the latter than really welcomed!



for only the second time and did not seem his usual self.

The 40-minute final started with Phil Greeno leading from Steve White and Peter Bervoets and that is the way it ended! Phil Greeno had just 10 seconds to spare over Steve White — both drivers having lost three laps at some stage of the race with mechanical problems. Ted Longshaw and Malc Draycott both had engine problems which relegated them to the minor placings, but altogether a successful day for the British contingent with four out of eight trophies.

Much colder conditions prevailed when Sports/GT started on Sunday morning: the blazing sunshine was replaced by a dull overcast day. After about six heats of the second round it started to rain and continued all day. The organisers cancelled the third round as nobody was racing, mainly because if you had not got a qualifying time you were not going to get one in pouring rain!

As on the previous day, Phil Greeno, Steve White and Peter Bervoets made fastest times with Etienne of Belgium in fourth spot. The semis took place with the water deep on the track. Ted Longshaw who had qualified for the semi could not run as the Rx in his car was soaked. Unfortunately he had kindly loaned his spare one to a French driver. Malc and Phil Draycott both suffered car barrel seizure in the rain — problems which made qualifying impossible. Goosemans, Denny Tassaux and the French driver who had borrowed Ted's receiver all went into the final.

The British contingent: Ted Longshaw (who lost his chance of the final by quixotic loan of his spare Rx) Steve White also with silverware, Phil Greeno, duly laden and the Draycott brothers who also managed a cup.



Phil Greeno took the lion's share of the silverware winning both Formula and Sports/GT events — a splendid return to form to round off the season.

The final was reduced to 30 minutes and took place in very wet conditions. Steve White missed the start due to a servo giving up the ghost four minutes before the off. Phil Greeno again led from start to finish making it a winning double of Formula and Sports/GT, followed by Denny Tassaux and Etienne, with Steve White in fifth place — that French driver with Ted's Rx getting in between.

Altogether a very successful weekend for the British team and Phil Greeno in particular.





Paul Padgin, British National
Champion GT



The SERPENT Mk III Pro 1979

is a proven winner — just
look at the British wins this season
Bournemouth F1 Bristol F1 (Easter)
Mendip Saloon, British G.P. Wombwell
Libre, Bristol F1 (July) Welsh G.P. Wrexham GT
British Nationals, Tibshelf GT, Mintex Bradford F1 & GT
IF SO MUCH CAN BE ACHIEVED BY SO FEW
AGAINST SO MANY — WHAT CAN THIS

CAR DO FOR **YOU !!!**



Peter Bervoets, European
Champion F/1

AMPS DOMINATE AT THE NATS

FTD SALOON
FTD FORMULA
FTD SPORTS/GT
1st SALOON
2nd FORMULA
1st SPORTS/GT

DIFFERENTIALS

Serpent Mk III
SG Futura
Delta Supa J
RC200/300
Challenger
PB int no mods
to standard car required

FROM
£30.95
Excl.
VAT

Now available: Micro-Diff for 1/12 cars **£9.95** Excl VAT

**AMPS LTD, STATION HOUSE, HARTHAM LANE, HERTFORD
HERTS. TEL: HERTFORD 56597**

Trade inquiries welcome • Prices shown excluding VAT

Serpent Mk III Pro £124.22 (Excl. VAT) 1979

STOP PRESS:
Belgian Grand Prix
2nd, 3rd, 4th in
Formula

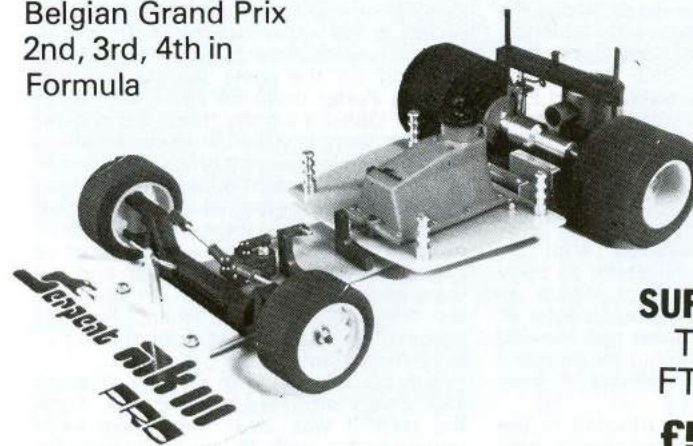

Use an
**AMPS MINI PIPE
MUFFLER**

for quiet power
£12.10 (Excl. VAT)

Why not try the

SUPERB NEW SERPENT
Tyres as used for the
FTD in GT at the Nats

£5.85 (Excl. VAT)

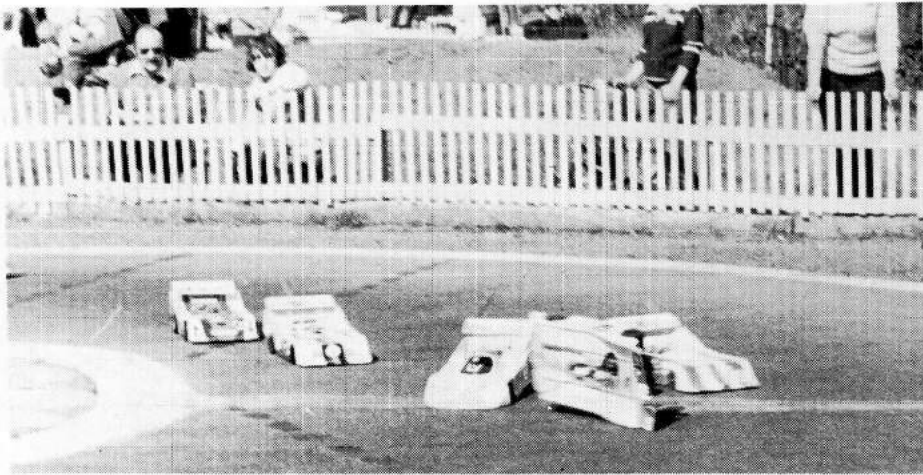

BRITISH NATIONALS AT TIBSHELF

BRIGHT sun, safe green outfield, a well stocked beer marquee, and the occasional click of bat on ball from the adjoining cricket match coming between staccato engine noise, gave the three day holiday meeting at Tibshelf a friendly carnival air. Add to this the tallest rostrum in the land (18 feet at eyelevel I was told) seventyfive trophies to be won, a near capacity entry and you have the picture. Just to make everybody, or nearly everybody, happy the prizes were distributed with splendid diversity: Debbie Preston took the Saloon with an Associated; Phil Booth and Formula driving PB International and Paul Padgin the Sports/GT with his Serpent.

Meeting was sponsored by Ovoline Oils, the family business now over a hundred years old whose lubricating oils hold sway over the Midlands and the North. Lapel badges for the company and slide transfers were in evidence and the company had supplied flagstuffs to carry national and company flags which all added to the jollity. Managing Director E. M. Brett presented the prizes and showed so much interest I should not be surprised to find him on the start line one of these days.

As usual Saturday was devoted to the Saloon event which attracted seventy nine entries. Since a number of entrants from more distant parts do not attempt to arrive

before the evening it usually gives local talent an early opportunity to shine. However, local talent is unusually strong in the Tibshelf area so that we had the Prestons, Steve White and Paul Padgin plus Walter Bailey, almost on the doorstep, so that visiting newcomers were somewhat swamped. Debbie won on 103 laps (only three laps slower than Phil Booth's Formula win) after a ding-dong struggle with Paul Padgin two laps behind. Paul also made FTD in the high 17s.

The Handicap Finals also produced some keen racing, though Ian Kerry skated away to an eight lap win after some sharp racing in the earlier stages of the event. The 20% plus final found three leaders finishing on the same lap, Mason just beating Porter (both on 25%) with Brian Palmer (35%) a worthy third. It is a great pity that there is still a Cinderella air about the Saloon class since it offers so wide and interesting a range of bodystyles, such as the Corvette Stingray (which was indeed, in evidence) if only there could be some modern direction as to exactly what is eligible as a saloon. Two years ago we were eagerly promised such an approved list from a committee man, but his progress is in part like the mills of god . . . exceeding slow.

A full house entry on Sunday of some 120 drivers promised great things. From the start it was clear that times were getting better, with 18 laps mandatory for any chance of further participation. The very attractive Lotus 80 bodysell was a

popular choice. It has the great asset that, unlike so many shapes, it needs only minimal cutting away for access holes, leaving more body covering. Walt Bailey had dressed his in British Racing Green with stickers galore to make an attractive, if rather dull, ensemble. Walt assures me that it is fully visible even on the grass outfield whose colour it is supposed to match. More attractive was another I saw in white using the latest PB transfers which provide an instant stripe effect. Keith Plested incidentally is now all for a black and yellow colour scheme after seeing how the Japanese entries at Geneva stood out a mile from any angle.

Debbie Preston made FTD and was accompanied into the final by Phil Booth Walt Bailey and Phil Greeno. Semi-final qualifiers were Dave Preston, Steve White Fred Martin and Keith Plested.

Five of the eight finalists exceeded the hundred lap figure with Phil Booth showing his accustomed expertise at the head of the field, ably pitmanned by Ted Longshaw, with 106 laps, followed home by Steve White (105.05) and Dave Preston (105.10). Debbie was a couple of laps further back hotly pursued by Walt B. Keith was getting radio interference on the far straight every lap and dare not open up.

This time the low Handicap Final proved the more exciting with only a few seconds between first and second in the shape of Trowbridge and Church, with another battle going on between Wright and Sorge for the minor places. The hi handicap



Mrs DeBoo presents Paul Padgin with the DeBoo Memorial Trophy for his Sports/GT win.

event went to Porter who had taken second place in the saloon event on the previous day.

Fittingly, Monday with the Sports/Proto field in full strength proved the best day of all for speed and thrills. For the first time at Tibshelf the magic 19 laps was breached which means that average lap time must be below 16secs. Steve White did it first, then Paul Padgin, then Steve beat him to regain FTD: then in one heat we had three 19 plus times Fred Martin (19.11.1) Phil

Heading: A regular first corner jostle at the start!

Below: Reputedly the highest rostrum in the land!





Phil Booth winner of Formula Event with his trusty pitman Ted Longshaw.

Phil Booth again — this time receiving a framed photo of his world beating run at Geneva presented to him by Mrs DeBoo on behalf of the BRCA.

Debbie Preston won the Saloon Event — shown here with her prestigious pitman Bob Errington.



Booth (19.12.1) and Debbie Preston (19.13.8). With such splendid times all looked set for a magnificent finish to the meeting.

Alas, the ugly spectre of radio interference which had been dogging heats every day reared its ugly head in the final. After a very few laps it was clear that some cars were not answering the helm, and BRCA Secretary stopped the race as EFRA Director presumably under Rule VI(a). Radio boffin Jeff Lindstrom was quite unable to track down a culprit as no interference showed on his screen. Phil Booth however could not get an interference free run and did not take part in the race. Dave Martin was in like

straits but soldiered on until it was clear he had no control on the last straight before turning across the rostrum. He ploughed into the end fence twice at full speed and that was the end of his effort. This left it as a six-race final only which then proceeded to become the kind of race we had expected or at least hoped for. Ted Longshaw made it even more exciting for spectators with a masterly and clear race commentary. First we had Debbie Preston racing away in the lead for the first third of the event until alas her engine blew up. Paul Padgin then took it up to lose the lead to Bob Errington. These two raced round neck and neck with seldom more than a few lengths in it with frantic manoeuvring at possible and impossible corners. Tibshelf we should add is made up of a series of straights joined by hairpins. The first two straights have a sweeping banked bend that can be taken with very little cut off. Then Bob

Errington went in to re-fuel 5½ minutes from the end. Would he have enough to last out? Paul was in front, then Errington regained the lead. Paul went in to re-fuel (his should certainly last him) Bob Errington was then about ten seconds ahead. With three minutes to go Bob felt it safe to go in for a squirt of fuel. Excitement! His engine cut and re-start used up his tiny lead. Paul ahead again, but Bob catching him about twenty yards per lap — can he do it? — last minute still closing fast when he spins out letting Paul Padgin coast in to take the race for Serpent. Verdict: one of the most exciting finals I have watched.

Then followed the presentation of awards in the hands of Ovoline MD. Mr E. M. Brett. First came surprise boxes of chocolates for the timing team Muriel Russell, Chris Newman and Les Lindstrom who had tackled the scoring so admirably, assisted by Mick Wright at the microphone as heat caller and main commentator. Trophies went to the finalists in every event, a total of seventyfive trophies in all.

SALOON

Open	laps	0 — 15% Handicap	20% + Handicap
1 Debbie Preston	103	I. Kerry 40	F. Mason (25%)41
2 ●Paul Padgin	101	P. Leach 32	J. Porter (25%)41
3 Dave Preston	87	N. Scase 27	B. Palmer (35%)41
4 Walt Bailey	85	M. Williams (10) 20	J. Harrop (40%)39
5 Fred Martin	84	E. Church 17	R. Winder (25%)18
6 Steve White	78	A. Wright 14	S. Wragg (20%)14
7 M. Draycott	65	A. Wilson 9	W. Jepson (30%)10
8 A. Ward	29	A. Stafford (5%) 4	S. Byrne (20%) 3

● Fastest Qualifying Time of the day

FORMULA

1 Phil Booth	106	D. Trowbridge 47.14	J. Porter (25)45
2 Steve White	105.05	E. Church 47.18	R. Heffer (20)41
3 Dave Preston	105.10	A. Wright 46.16	S. Byrne (20)39
4 ●Debbie Preston	103	P. Sorge 46.18	K. Broadbent (25)40
5 Walt Bailey	100	I. Cowieson 44	C. Wilson (20)38
6 Phil Greeno	94	R. Darby 29	C. White (30)41
7 Fred Martin	73	A. Wilson 23	P. Young (25)36
8 K. Plested	57	P. Leach 13	W. Jessop (30) —

● FTD

SPORTS/GT

1 Paul Padgin	110	A. Wright 48	J. Darrington ? 49
2 Bob Errington	107	E. Church 46	J. Lindstrom (30) 50
3 Fred Martin	104	I. Cowieson 45	N. Heighton ? 43
4 Keith Plested	103	P. Leach 43	C. Wilson (20)39
5 Dave Preston	100	D. Trowbridge 43	C. White (30)31
6 Walt Bailey	81	M. Williams (10) 42	D. Beatty ? 28
7 Debbie Preston	67	R. Darby 34	R. Winder (25) 16
8 ●Steve White	25	I. Kerry 20	M. Futter ? 9

● FTD and new Track Record 19 laps in 5min 08.2 secs.

Among the winners was numbered Ray Heffer, who organised the meeting so ably, and to be sure he got a very special round of applause. Finally came two additional presentations which were made by Mrs DeBoo. First she gave Paul Padgin the DeBoo Trophy, a perpetual Challenge Trophy to be held by the winner of the National Sports/GT event, which he will hold for the next twelve months. Then followed a BRCA award to Phil Booth to mark the association's appreciation of his World Championship achievement. This took the form of a splendid action photograph of Phil's car crossing the line at Geneva with the crowd waving and applauding madly.

Altogether a very satisfactory event, made possible by generous sponsorship, excellent local support, and the fulfilment of all the pledges made when taking on the event — namely a good circuit, adequate management, catering facilities and toilets with full co-operation all round — I even saw an Ovoline staff man taking the tickets at the gate!



FUTURA III



EUROPEAN CHAMPIONSHIPS — NUREMBERG. AUG. 11/12.
GUILIO GHERSI WINS WITH FUTURA III AND S.T. X21RE.

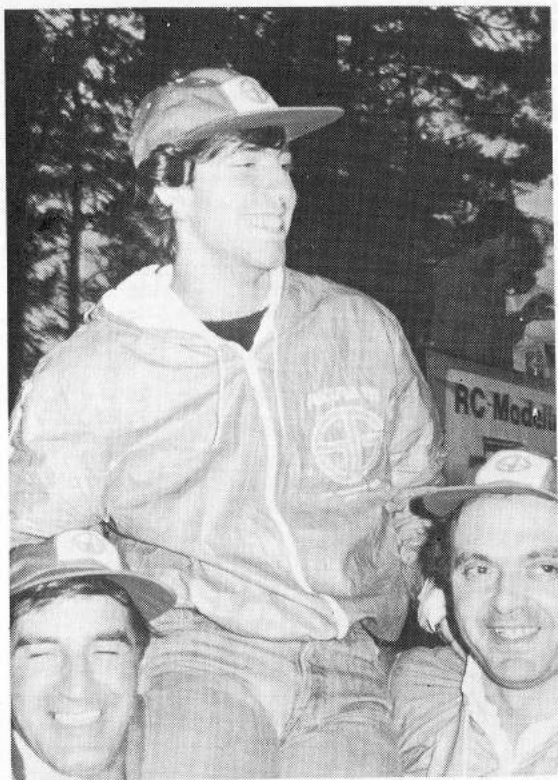

FUTURA III STANDARD

Engineered by Franco Sabattini. Designed for serious racing at National and International level. Inc. ABS Bodyshell. **£73.45**

FUTURA III SPECIAL

Part built, plus SG differential, brake adjuster/accelerator linkage, Akerman centre point steering, glass fibre chassis, Teflon clutch shoes, floating servo saver support. **£122.45**

Distributed by:—

MODEL RECTIFIER UK LTD.
EAST WOOD, BEVERLEY ROAD,
WALKINGTON, N. HUMBERSIDE HU17 8RP.
TEL: (0482) 882311. TELEX: 527584.

NEW SANWA

Mini Propo



GC-2200E

Big on performance
— light on your
pocket — here's the
sport R/C system
you have
demanded.

Here's a radio control system you can buy without breaking the bank — or even the piggy bank! The new Sanwa GC-2200E and GC-3300E offer two or three function control with all the precision for which Sanwa has become known. You can start with dry battery operation to keep the cost down initially and then add rechargeable Nicads if you find you need them.

£49.95

With 2 servos and dry battery operation

Next time you go to your model shop ask to see the GC2200E and GC-3300E systems — we know you'll like what you see!

GC-3300E — 3 channel with 2 servos — £55.25

NEW TRANSMITTER 6.10" x 5.51" x 2.04" compact size 12.3oz (less batteries) weight. HIGH OUTPUT, TRUE OUTPUT METER. Provision for fitting nicads charging socket incorporated.

Tx/Rx Nicad packs and charger
£37.95

RECEIVER 0.80" x 2.56" x 1.88", 1.76 oz. SENSITIVITY 50 Micro volts/meter. Output + pulse 3.5v.

For further details consult your local IRVINE-SANWA dealer or send large S.A.E. to:

SERVOS NEW ROBUST DESIGN. Size 1.53" x 0.78" x 1.61". TORQUE 2.5kg/cm (34oz/in). Transmit time .3 sec/80 deg. Weight 1.58 oz.

IRVINE



SANWA

Irvine Engines Ltd., Unit 8, Alston Works, Alston Road, High Barnet, Herts. Tel: 01-440 0923.



ROBERTS WINE STOX FIESTA

Mayor of Worthing Iris Price presents Dave Wragg with his winner's trophy.

THANKS to the generosity of local sponsors Roberts Wine, part of the Courage group who put some £400 into the meeting, Southern Radio-Car Club were able to promote their second Fiesta Meeting on the Worthing Civic Centre car park with every confidence, particularly as the event had assumed something of an international nature with a good entry from Holland. A very wet Saturday before the meeting produced a degree of gloom as



drivers began to arrive, but happily the sun came back on Sunday and quickly dried out the track.

Worthing's Miss Fiesta Kelli Jones arrived at 10.15 to judge the Mardave Concours event which went, most worthily (no pun intended!) to Chris Cowlam from the Leicester club. By 10.30 the first round of heats was away with some sixty plus drivers contesting fortyfour heats spread over four rounds so that each driver enjoyed four races. Round 1 found World Champion Dave Wragg sharing the lead at 40 laps with fellow Leicester driver Bob Clayfield. Steve Talbot, World Champion in '76 was close up with a 38 lap score. Dutch driver Ernst Aalders, World Champion of the European Stockcar Association, had a disastrous first heat, scoring a scant 20 laps, enough virtually to eliminate a driver at this level of competition. Round 2 was a carbon copy of Round 1 with British National

Heading: The Final: L to R, Roger Bye, Dave Wragg, Chris Price, Ron Bekking, Paul Hancox, Brian Sylvester.

Champion Roger Bye joining the elite 40-lappers, and taking 3rd place with a score of 73.

Following the lunch interval a really hot afternoon brought the spectators flocking in to pack the circuit. Round 3 provided a slight falter amongst the leaders with Dave and Bob scoring 38 laps apiece: Ernst Aalders back in form leading the round with 39 laps. Paul Hancox, an alleged novice driver from Studley Club put in a blistering 37 laps with his Puma kit car to take 8th place overall. The 4th and final round gave local club driver Miles Taylor (yellow roof) a chance to shine with his best ever drive of 37 laps, a club record for the Southern Club. Dave Wragg took the honour again with another 40 laps but Bob Clayfield fell back with engine problems to score a mediocre 29 laps.

After the usual crystal changes, semi got under way. Hardest luck story goes to Steve Talbot who had qualified in 2nd place. Three minutes into the race he had

Above and Below: The Start: Ready... Go! (But different heats!)



Mardave Concours Trophy Winner (Chris Cowlam, Leicester).

a 'close encounter' with Dutch driver Ron Bekking, and hit the outer barrier, shearing his front stub axle — and so went his final chances. British World Champion Dave Wragg again came through a comfortable winner, whilst his teammate Brian Sylvester who had almost unnoticed put up some good scores during the day, quietly eased into the final with 38 laps. Finalists then were: Roger Bye (Chessington) Dave Wragg (Leicester) Chris Price (Chessington) Ron Bekking (Holland) Paul Hancox (Studley) Brian Sylvester (Leicester).

The final began at 6 o'clock with Worthing's Mayor and Mayoress and the directors and management, of sponsors Roberts Wine Merchants as keen spectators. Cars were brought round in close formation for a rolling start, and, as the hooter sounded, the very noisy car of Dutchman Ron Bekking powered into a half straight lead, closely followed by Dave Wragg and Brian Sylvester. Roger Bye from Chessington was suffering severe engine problems, and despite furious efforts by his mechanics was forced to retire from the fray. Three minutes in and Ron Bekking remained comfortably clear of Dave Wragg. Studley driver Paul Hancox improved his position, with Chessington Chris Price tight behind. Suddenly Ron Bekking's car lost a drive belt and in an instant his mechanic had replaced it and was ready to return the car to the track. But — disaster! — his oily rag became entangled in the rear wheel and axle. Feverishly he tried to get it off, but some twenty seconds passed before it

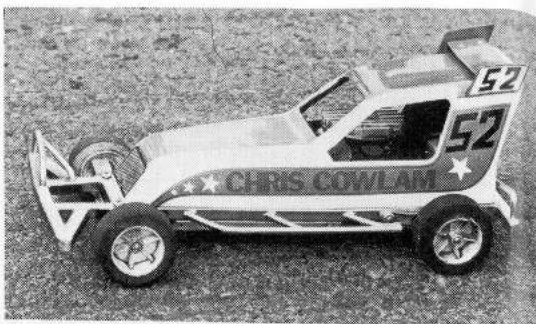

freed. Inspired is the only way to describe Ron's driving as he fought his way back, encouraged by the cheers of his clubmates. Meanwhile the crowd were cheering on Dave Wragg for Britain. When the final hooter blew there was spontaneous applause for the sheer quality of the race.

Then followed the conclave of the three sets of lap scorers (prudently insisted upon by the Dutch boys) who confirmed the result as: 1st Dave Wragg (50 laps) 2nd Brian Sylvester (48) 3rd Paul Hancox (47) 4th Ron Bekking (47) 5th Chris Price (47) 6th Roger Bye (32). Trophies went to all six finalists with a splendid 2ft high cup to winner Dave Wragg. Team award went to Leicester with his team mates John Orton, Stew Busby, Tony French and Brian Sylvester, with a total of 526 laps, 45 laps better than second placed Dutch team.

It proved a truly wonderful day, enjoyed by all, in spite of an occasional hassle between British and Dutch teams, which seem all part of the game. The event also raised the useful sum of £100 for the worthwhile Gunnar Nilsson Cancer Fund. Now for next year. . .

NEWS FROM THE ALPS!

parma
INTERNATIONAL INC.

Phil Booth won the
2nd World 1/8 R/C
CHAMPIONSHIPS
WITH PARMA'S
KROLL BODY

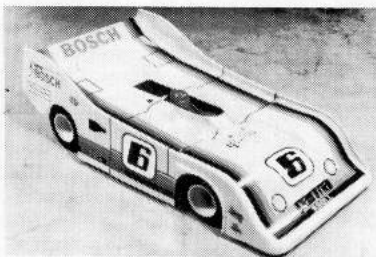

Try our
Parma
bodies
for a winning
performance

parma

13927 PROGRESS PARKWAY
NORTH ROYALTON, OHIO 44133, USA

★ FOR ALL THAT IS BEST IN R/C MODELLING • • • **MICRO-MOLD**

THE M.M. 1/12 SCALE ELECTRIC RACING CAR

The new MM Car has been designed with beginner and expert in mind. Construction is simple for the beginner with the aid of the well illustrated and comprehensive assembly instructions and the expert will find features such as adjustable wheelbase and alternative mid or rear engine mounting positions ideal for tuning the car to a particular circuit.

Available with our own Wolf WR5 Formula 1 or Capri GT bodyshells or any of the wide range of BoLink bodyshells.

- * STRONG PREFORMED ALUMINIUM CHASSIS AND BATTERY TRAY
- * RIGID MOTOR AND REAR AXLE MOUNTING TO ENSURE PERFECT GEAR ALIGNMENT
- * NYLON BEAM FRONT AXLE WITH INDEPENDENT COIL SPRING SUSPENSION
- * HEXAGONAL REAR AXLE RUNNING IN NYLON BEARINGS
- * POWERFUL ASTRO 05 MOTOR
- * EVER READY 6 CELL 1.2 Ah BATTERY PACK
- * SERVO OPERATED REVERSING SPEED CONTROLLER
- * SPRING OVERRIDE SERVO SAVER AND BALL JOINT STEERING LINKAGE
- * TOUGH NYLON WHEELS WITH SPONGE TYRES
- * CHOICE OF BODY TYPES
- * HOOK UP WIRE, CHARGING LEAD AND CHARGE RESISTOR INCLUDED
- * FULL RANGE OF SPARES AVAILABLE INCLUDING ALTERNATIVE TYRES

BOLINK BODY SHELLS FOR 1/12th ELECTRIC CARS

These are top quality clear body shells moulded in extra strong Tufftak.

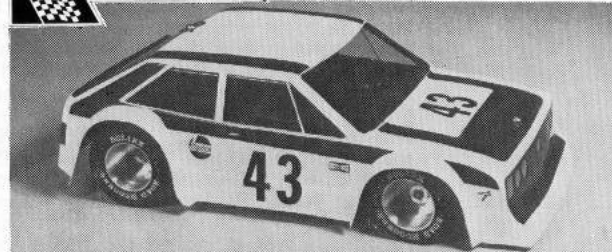

◀V.W. Scirocco	
BL42 Datsun 240Z	£4.53
BL45 Cheetah	£4.53
BL46 Chevron F1	£4.24
BL48 75 Camaro GT	£4.53
BL54 Ferrari 312 B 3(T)	£4.24
BL55 Street Porsche	£4.53
BL56 Monza GT	£4.53
BL57 Datsun 280Z	£4.53
BL58 Ferrari 312P Can Am	£4.24
BL59 Ford Custom Van	£4.53
BL60 Chevy Custom Van	£4.53
BL61 Shadow Can Am	£4.24
BL62 Midget Sprint car	£4.24

BL65 Porsche 935 Turbo	£4.53	BL72 Lamborghini Countach	£4.53
BL67 Ford Pick Up	£4.53	BL73 Mini Cooper	£4.53
BL68 Mazda Rx 70	£4.53	BL74 Porsche 935-78	£4.53
BL69 Mercedes 500 SLC	£4.53	BL75 Porsche 917-K GT	£4.53
BL70 Spyder Can Am	£4.24	BL76 Nascar Oldsmobile	£4.53
BL71 VW Scirocco	£4.53	BL41 McLaren M26B	£4.24

BoLINK
Industries



MICRO-MOLD Station Road • East Preston • West Sussex • BN16 3AG



BP-HADLEY CITY GRAND PRIX

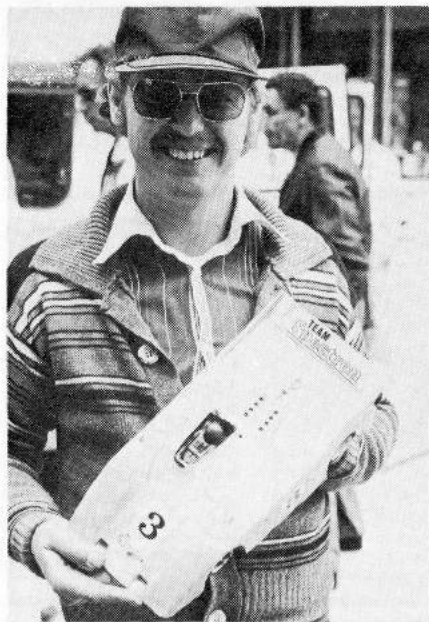

THE BP-Hadley Hobbies r/c Cars Extravaganza in the City Carnival Week in July provided a splendid forum to exploit the radio model car angle and that benefit alone more than justified the immense amount of work and worry involved. A further benefit was that some 6,000 Souvenir Programmes were sold for the Lord Mayor's charity — Motability and such was the interest shown in the cars that some City slavedrivers, they say, complained that their slaves were not getting on with their work but actually looking out of the windows and getting distracted!

It was a long week run to keep up the enthusiasm and interest with a mixed bag of competitors ranging from the highly expert, in small numbers, down to absolute beginners. Of course, there were distractions such as the Big Money Men's race with people like the Chairman of the Stock Exchange Nicholas Goodison, Barclay's Chairman Sir Anthony Tuke and Lloyds Chairman Sir Jeremy Morse starting proceedings — Mr Goodison won by the way. Then there was Playboy Bunnies versus Penthouse Pets — I don't know who won this but I did hear that *Penthouse* was doing an r/c model car feature — wonderful excuse to subscribe to *Penthouse*, as if one was needed. By the end of the week Richard Gammon who was Race Controller and Graham Colover of Hadleys Hobbies had certainly

Imposing City setting as drivers look down from their Whitbread Dray rostrum. Left: The Big Winner John Chamberlain of Team Spectron.



learned a great deal about running races, met a lot of people and done a lot of useful propaganda.

I went along for the Saturday Finals (a big change after Geneva!) to find a fair crowd making the most of a blustery summer's day. A Whitbread's dray made an excellent rostrum for drivers, and one of those small business man's d.i.y. computers had been skilfully programmed to produce instant race results. However, I think too many races had been scheduled for that final afternoon as the programme got sadly behind. Prizes were awarded as events finished and Dickie Kohnstam was able to present his Tamiya Class awards from the rostrum in good time to Neil Francis of Sutton Coldfield, the winner, followed by Tom Morgan also of Sutton Coldfield, with young Jon Moulton in third spot. Concours d'Elegance went to Colin Spinner and Team Race winners proved to

be Team Spectron — a nice surprise for hardworking Richard Gammon.

The Grand Prix Champion was John Chamberlain of Maidenhead who won the week's luxury holiday in Spain donated by Rankin Khun Travel plus the City Grand Prix Cup. He also took the Hobbycard Cup for fastest time over twenty laps. Les Pipe of Hinckley also won a holiday for four at Pontins Brean Sands Hobby Festival and 2nd place cup. Number 3 was Tony Devonport who took a Minimac 2-channel outfit donated by MacGregor Radio plus 3rd place cup.

Altogether a most interesting week with Spectron taking the lion's share of the awards. Lessons learned I think include the important one that a whole week is too long — a two day event could maintain the pressure better. But for a first time venture by both Hadley Hobbies & Richard Gammon it went off very well.

Neal Francis, Sutton Coldfield, a regular winner, took the Tamiya Class event.

Peter Horne with his Lotus 79 a splendidly decorated and finished scale model.

Colin Spinner, Concours Winner with his amusing open Mini.

The Stox Winners: Dave Woods and Roger Bye who worked very hard for their tankards.



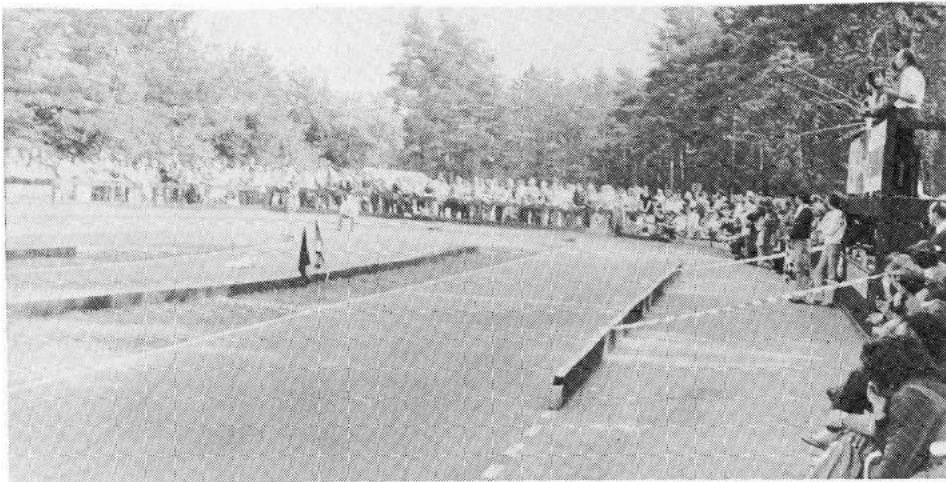

EURO CHAMPS: NUREMBERG

A SERPENT driven by Peter Bervoets took the Formula event at Nuremberg: and Ronny Ton only failed by some three seconds to achieve an amazing double for the marque in the Sports/Proto final when beaten by Italy's Gheri driving his SG Futura in a stupendous finish. But behind these two memorable victories lies a weekend of frustration which must be told.

The circuit lies just outside the city limits in beautiful wooded country — with cranberries and blueberries there for the picking — and was the first purpose built track to be operated in West Germany. As such it may be considered a little narrow for present needs, only just wide enough to take an eight-start event, but with a delightfully smooth surface in the dry and very little that cars can do to harm themselves anywhere. In wet weather it is almost undrivable with a glass like surface that rain tyres struggle in vain to overcome.

Even quite early arrivals a week before racing started were disappointed to find the camping site already full, and had to camp out in the woods without water or sanitation (Perhaps this explains Paul Padgin's newly started beard?). However, weather was fine until the Thursday and practice proceeded happily. Friday the weather deteriorated and on Saturday morning when the qualifying heats for the Formula event began it proved almost impossible to run rain heats as laid down under the rules since cars were hardly managing to get round. Fortunately

weather improved, the rain stopped and it was possible to ignore the wet runs — casualty here was Phil Booth with two wet runs and a failed servo on his only dry attempt. He had the doubtful honour of being bottom of the list! Sometimes you win; sometimes you lose.

Throughout the day it had become increasingly plain that timing was not up to championship standard and most teams were taking careful timing checks. Four through into the final direct with 19 laps plus proved to be Phil Greeno, Bob Errington, Reiner Heller of Germany and Peter Bervoets, Holland. First semi went to Hans Johansson of Sweden driving the interesting new kit car the Carlsson with its hub-enclosed diff — straight out of the box he claimed. Dave Martin came 2nd a lap behind. The second semi proved a ding-dong struggle with three on the same lap, and two more only a lap behind, final places going to Gheri and Debbie Preston — Steve White the third 69 lap-er being the unlucky one by a few seconds.

The final started quite happily with Peter Bervoets leading the field, until after twelve minutes the black flag stopped the event. A somewhat embarrassed organiser explained that something had gone wrong with the timing mechanism and he had no times after twelve minutes. Everybody hung around for some half hour with various huddles until it was decided to continue the race with by then restored timing for the remaining 28 minutes. This duly happened and after the allotted time it appeared that Phil Greeno had won from

Peter Bervoets with his hardwon trophy and the car that achieved it, after some 250 plus laps!

Peter Bervoets. This was by no means certain as there were two schools of thought — but Peter was quite resigned to his second place. Meanwhile, however, the Italian team had registered a formal protest that the whole split race idea was wrong. The international jury consisting of the Race Director, Team Managers and EFRA reps as set out in the rules crowded into the small caravan-office and talked and talked . . . until the light failed. Three options were (1) to declare the Formula event void and cancelled for 1979 (2) to accept the result (whatever it was!) (3) to re-run the race. The last choice was taken and the race re-run on Sunday morning at 8.30 am. I was not there but am informed that no practice time was allowed drivers went straight out and raced.

This re-run event was won by Peter Bervoets with 120 laps from Hans Johansson of Sweden (115), Dave Martin (109). All credit to Peter Bervoets who now enjoys the distinction of having raced more laps for a single trophy than any other international driver (must be well over 200 laps in all!) Congratulations Peter, it is nice to have beaten your jinx that so far always seemed to put you 2nd!

(A sad thing about it all is that the highly efficient Wiesbaden timing gear was available on loan but the organisers were unwilling to pay the hire charge very

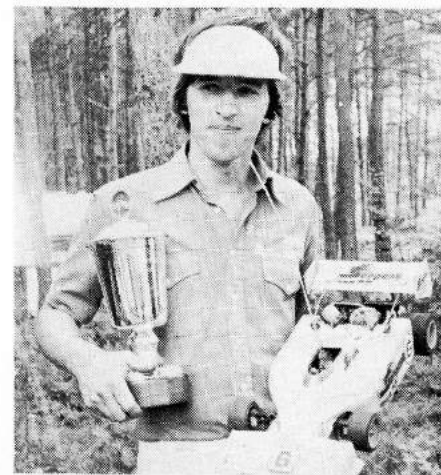

reasonably requested. No stand-by timing apparatus was in use. All this trouble was unnecessary)

After this early start to Sunday the weather brightened up considerably, and what must be a record crowd began to arrive. Porsches were as common as Cortinas in the crowded parking areas, and a beautiful Dino Ferrari from Basle vied with an immaculately restored Citroen Light Fifteen as the Queen of the park. With finer driving conditions the general

Heading and below: These two pictures give a good impression of the circuit and the excellent Sunday afternoon attendance.

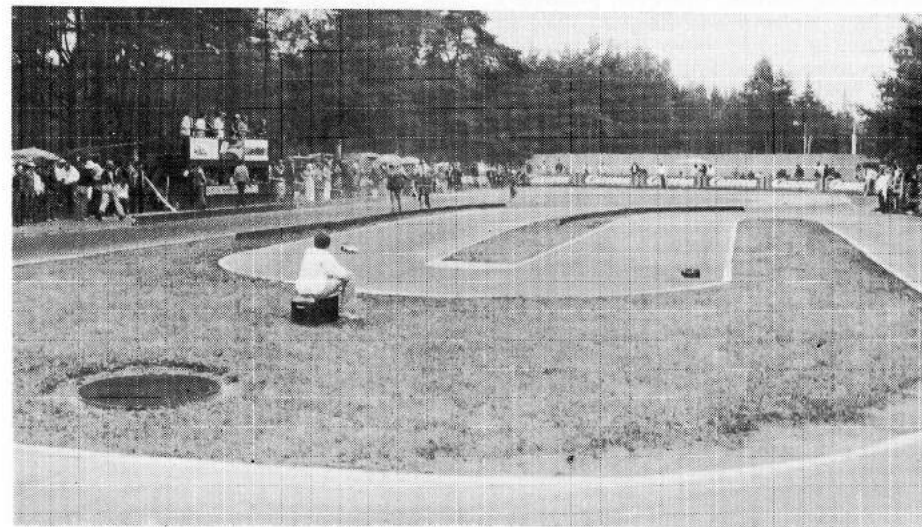

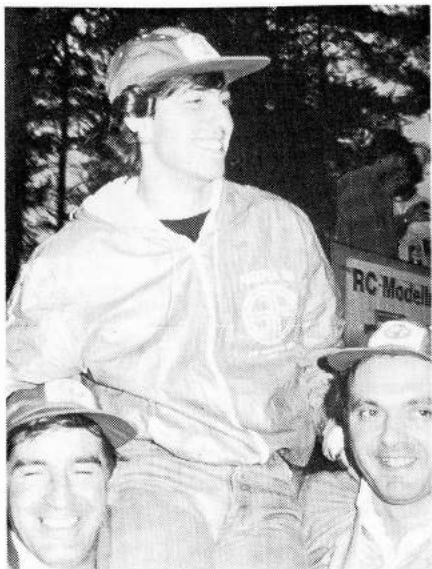

Guilio Gheri lifted aloft after winning the Sports/GT race — a magnificent feat of driving. Franco Sabbatini on the right looks over the moon!

the list of times instead of alternating times to distribute the top men equally between the two semi-finals. This took quite a time to arrange, including problems of frequencies. I had three separate sets of semi-finals in my note book before the true and official set was agreed.

Back to the second semi: here Swedish driver Johansson won from Peter Bervoets with Paul Padgin the unlucky third. Although all three were on the same lap, miraculously the timekeepers got the order right without challenge.

Now for the Final! Almost from the start Gheri dominated the race, and indeed was never placed lower than second at any stage. Close on his heels for the first few minutes were Dave Martin and Swede Johansson with Ronny Ton not far away, and a momentary showing in second place by Swiss Wiedler. From about the twelfth minute it resolved itself into a needle match between Gheri and Ton with Johansson occasionally intervening, and the steady Dave Martin in fourth place waiting for the mistakes which never came. After 25 minutes Gheri was nearly two laps ahead of Ton with Johansson a further two laps back. Then at 30 minutes, Ton got onto the same lap as Gheri and began to close steadily a few yards per lap, until at about minute 33 he forged ahead in the lead. It was but a momentary flash in the pan, with five minutes still to go Gheri reclaimed the No.1 spot. Ton was about half a lap behind, and again began to close until the last minutes when it looked as if there might be only lengths in it, but as the pair raced for the finishing line Ton spun round and lost his impetus, leaving Gheri to win by some forty yards and three seconds! Gheri drove an impeccable race maintaining a perfect line for lap after lap and it would have required a super man to beat him on that form. Ronny was very nearly that man, always fractionally faster but nothing like so steady and free from over impetuous run outs.

Then the kissing had to start. The Italian team all kissed each other and Gheri like a Cup Final goalscorer — only good footwork saved me from a couple myself — and a jubilant Franco Sabbatini helped hoist the victor aloft in traditional style. It was a great occasion and a deserved win.

Technically an interesting meeting with Serpent cars doing very well — almost a double win — with three cars in the Sports

atmosphere of brotherly love was much improved and 20 lap heats began to appear with 19s very thick on the ground. Fastest four to the final proved to be Dave Martin, Ron Ton, Gheri and Wiedler of Switzerland.

Alas for the brotherly love, first semi produced three men on the same lap Phil Greeno, Franzel Groeschl and Dennis Tassaux. General opinion — shared initially by the official timekeepers was that Groeschl had won from Greeno with Dennis a lap behind. However, protesters from both Holland and Belgium claimed that Dennis should have been credited with an extra lap putting him at the head of the field. Again the jury went into a huddle and it seems that some threats of withdrawal were voiced if the missing lap was not allowed (I give this as the current hearsay, mark you, I may be doing someone a grievous wrong and apologise in advance!) So in due course that lap was found. Since re-fuelling took place rather out of the time judges' line of vision in front of their box, it was woefully easy to miss a lap and with no back-up timing the error was hard to detect. I should add that Phil Greeno (already with a near victory snatched from him the day before, and the victim of losing a final place here) played no part whatever in the argument and took it all in a most sporting manner.

I must also add that the arrangement of semi final heats caused another protest when the race director went straight down

Typical start: Look guv' — no hands!

Final (Ton, Bervoets, Tassaux) plus Steve White and Paul Padgin in the semis. Incidentally, Paul's pitman John Russell made the trip to Germany solely to pit for him all for the good of the Hobbycard/Serpent team. Then a new star seems to be rising from Sweden in the shape of the Carlsson kit (soon to be built and reviewed). Also to be noted was Reiner Heller with a Carrera, one of the four fastest in the Formula heats. Most of the EFRA countries were there including Spain, Lichtenstein, Austria, Jugoslavia. . . in fact only absentees were Ireland and Denmark. But what a pity that a rather



inexperienced team was left to run the meeting without Headquarters help and guidance.

RESULTS

Formula

Semi Final I

Johansson, Hans	S	72
Dave Martin	GB	71
Per Gustafsson	S	69
Elias, J.	NL	67
Paul Padgin	GB	66
Goosemans, J	B	60
Orazi, V	I	56
Vasselli, Sandra	I	23

Semi Final II

Gheri, G	I	69.5:6
Debbie Preston	GB	69.14:8
Steve White	GB	69.20:4
Groeschl, F	D	68
Veronesi, S	I	68
Rune Carlsson	S	66
Guiette, E.	F	61
Marzocchi, M.	I	47

Official Final

1 Peter Bervoets	NL	Serpent	OPS	AMPS diff	120.66
2 Hans Johansson	S	Carlsson	K & B	Carlsson	115.11
3 Dave Martin	GB	PB Int.	OPS	PB	109.83
4 Bob Errington	GB	PB Int.	OPS	PB	108.11:7
5 Phil Greeno	GB	Greeno/PB	OPS	PB	106.17:8
6 Debbie Preston	GB	Associated	OPS	AMPS	102.26:5
7 Reiner Heller	D	Carrera	K & B	Carrera	91.14:8
8 Gheri, G.	I	SG Futura	STX21	SG	80.7:03

(12 Minute Final: Bervoets 28 Minute Final: Greeno)

Sports/GT

Semi Final I

Tassaux D	B	76
Groeschl, F	D	76.82
Greeno, P.	GB	76.88
Gabbiani, P	MC	75
Booth, P.	GB	73
Naser, J.	D	73
Sabbatini, F.	I	

Semi Final II

Johansson, H	S	75.0:9
Bervoets, P.	NL	75.8:3
Padgin, P.	GB	75.15:2
Heller, R	D	69
Errington, R	GB	62
Vasselli, S.	I	61
Cromberge, F	NL	15

Final

1 Gheri, G.	I	SG Futura	STX21		152 3:7
2 Ronny Ton	B	Serpent	Picco	SG diff	152 6:8
3 Johansson, H	S	Carlsson	K & B	AMPS	151
4 Martin, D	GB	PB Int.	OPS	Carlsson	148
5 Bervoets, P.	NL	Serpent	OPS	PB	147
6 Wiedler, R	CH	SG Futura	STX21	AMPS	138
7 Tassaux, D.	B	Serpent	OPS	SG	136
8 Groeschl, F	D	Special	K & B	AMPS	97

ASSOCIATED RC12E 1/12 SCALE ELECTRIC

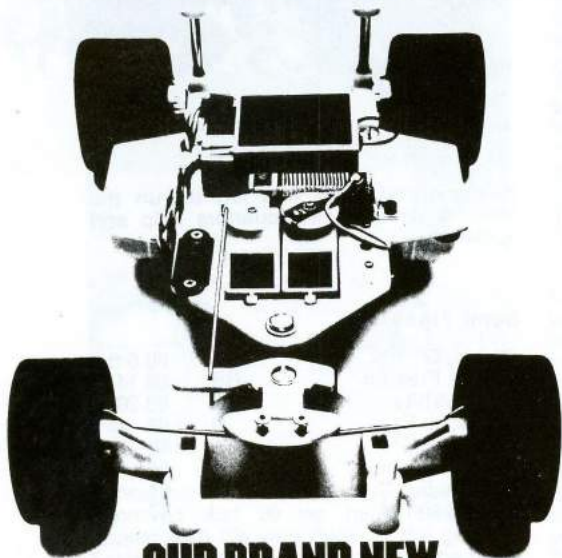

**OUR BRAND NEW
RC12E LOOKS LIKE A WINNER.**

IT SHOULD.

**WESTERN REGIONAL CHAMPIONSHIPS
THORP RACEWAY, ROAR SANCTIONED
134 ENTRIES**

Modified Class	Car	Motor
1 Gene Husting	RC12E	Reedy
2 Curtis Husting	RC12E	Reedy
3 Bill Jianas	RC12E	Reedy
4 Mike Rowland	RC12E	Reedy
5 Chuck August		
6 Bill Steele	RC12E	Reedy
7 Frank Killam		
8 Matt Azzara	RC12E	Reedy

Reedy Motors available from Associated
**RC12E wins all four 1/12 electric races at
1979 Roar Nationals**

ASSOCIATED, 1928 East Edinger, Santa Ana, CA.92705, USA

ASSOCIATED NEW 1/8 RC300

1979 INTER-CONTINENTAL RACES

Most teams have one or two Super Drivers. We believe our cars handle so well it enables more drivers to become Super Drivers EASIER and QUICKER. JOIN THE SUPER DRIVERS.

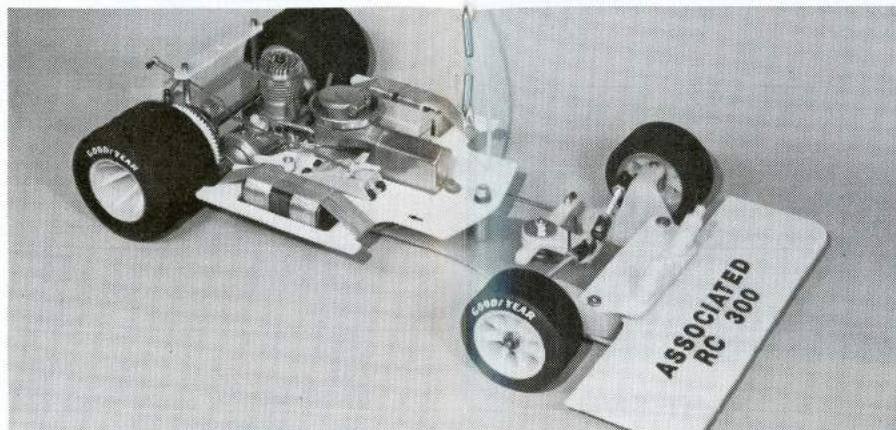

RC300



RICK DAVIS



DEBBIE PRESTON

At the WINTERNATIONALS race, BILL JIANAS qualified 1st with 32.8 laps, RICK DAVIS 2nd — 32.0 and JACK JACKOBS 3rd — 31.9. BILL JIANAS was in the lead at 65 laps when he lost a front tyre. At the WORLD'S CHAMPIONSHIPS, Ishihara from Japan qualified first, CURTIS HUSTING 2nd, JEFF ROLD 3rd, BILL JIANAS 5th and CHUCK PHELPS 6th. At 38 laps, CURTIS was leading with JIANAS 2nd and PHELPS 3rd. CURTIS'S engine locked up, JIANAS'S engine died twice and PHELPS ran out of fuel giving the lead to BOOTH. At WEISBADEN, CURTIS HUSTING was TOP QUALIFIER and the only car to turn 21 laps. JIANAS lowered the individual lap record to 14.0 seconds and DEBBIE PRESTON was TOP QUALIFIER from the Semi's.

WINTERNATIONALS ORLANDO, FLORIDA USA

1 Rick Davis	Associated	USA
2 Mike Rowland	Associated	USA
3 Gene Husting	Associated	USA
4 Phil Greeno	PB	England
5 Bill Jianas	Associated	USA
6 Roger Curtis	Associated	USA
7 Arturo Carbonell	Delta	USA
8 Phil Booth	PB	England
9 Keith Plested	PB	England
10 Jack Jacobs	Associated	USA

WORLD CHAMPIONSHIPS GENEVA, SWITZERLAND

1 Phil Booth	PB	England
2 Bill Jianas	Associated	USA
3 Chuck Phelps	Associated	USA
4 Fujio Sasuga	AAT	Japan
5 Naoki Ishihara	Road Ace	Japan
6 Rick Davis	Associated	USA
7 Jeff Rold	Associated	USA
8 Ronnie Ton	Serpent	Holland
9 Dave Martin	PB	England
10 Curtis Husting	Associated	USA

WIESBADEN GRAND PRIX WIESBADEN, GERMANY

1 Rick Davis	Associated	USA
2 Debbie Preston	Associated	England
3 Franz Groeschl	Scratch	Germany
4 Peter Bervoets	Serpent	Holland
5 Bob Errington	PB	England
6 Ronnie Ton	Serpent	Holland
7 Phil Greeno	PB	England
8 Curtis Husting	Associated	USA

Available from: **IRVINE ENGINES**



WORLD PART TWO CHAMPIONSHIPS GENEVA JULY 1979

A great deal of the interest for enthusiasts who were not in Geneva for the Championships must lie in the who and what of the meeting, with snippets of information, pictures of bits and pieces — not always of the leaders — and the things that come to light after the event. This part then is mainly pictures with places listed up to the cut-off point at 72, plus a short statistical piece.

Aftermath of a race always produces a host of "had I but knows" and Geneva was no exception. Curtis Husting could have continued beyond lap 38 if pitman (Dad) had given his rear wheel a good belt and freed an obstructing brake disc (or similar): as it was the car had all the symptoms of seizure and retired. I think every one of the five Americans in the final

led the race at one stage or another, perhaps a more co-ordinated race plan might have made all the difference. Phil Booth carried on steadily and only led at the end — the place that counts! I am told that Naoki Ishihara was promptly signed up by Associated's man in Tokyo on his return and so we may be seeing or reading of him winning for Gene Husting's Associated yet!

The Japanese one and all were gentlemanly drivers and able to keep out of trouble to produce magnificent heat times. In the hurly-burly-devil-take-the-hindmost of a ten car final (heats were 8 cars) the aggressive opposition played havoc with their cars and their ultimate placing was truly noteworthy. American racing, particularly on the car park type of circuit they are used to and enjoyed in Geneva is very much a no-quarter style of the over under or through type! I don't know who drew the cartoons embellishing these pages but they tell the story without words.

One quite remarkable picture was taken by the official photographer Monsieur Grin (a beautiful name for a photographer) which shows the flag coming down as Phil B. crosses the line and the crowd — over 5000 of them — beginning to wave, cheer and stand up in acclamation. An enormous enlargement of this suitably framed now hangs in the Booth household presented by BRCA as some recognition of his efforts.

Keith Plested did a swop exchanging a PB International complete for a Japanese car with its OS21ABCRC engine. This he has been running with some fabulous results. It is a true fuel miser running some 15 minutes on a tankful (125cc) more than double the customary distance. The car itself is not so light as had been believed but has a steering set-up very different from ours in Europe. His swapped engine had been run throughout the meeting but on taking it to pieces showed no signs of having been tuned by handwork and was good for a couple more meetings untouched. Everybody of course was mad keen to get hold of some of these OS21s and a quick hundred came into the wholesalers. Alas on examination — as Ted Longshaw found! — they were the wrong 21s — not the ABCRC variety desired. By now it is hoped the genuine articles have arrived to delight us.

THE NUMBERS GAME . . .

Writing in *Auto-Modell Technik* Sports Editor Hans Walther says: "Only those people who have already organised a World Championship of this size have a right to criticise the Geneva officials. "This rather narrows the field of valid critics, but for the benefit of future aspirants here are some interesting (frightening sometimes?) statistics.

Tickets sold: 6,000 plus free admission to 2,500 youngsters under 16. Welcomed: 144 drivers, 280 mechanics, 280 supporters, 700 guests, 120 guests of honour, 48 accredited journalists from model and specialist magazines from all over the world plus the Swiss press.

The meeting required 94 staff made up of 36 official organisers, 18 track marshals, 40 stewards, supervisors all of whom were fed and watered by the committee and consumed 370 meals, 400 beers, 750 Coca Colas, 140 litres of orange juice, 250 quarts Hennessey (what is this? Ed) 60 litres red wine. There were 240 people at the banquet including 58 guests.

In the Pits 144 competitors came from 18 different countries made up car-wise of 44 Associated, 27 PB, 14 SG, 5 Challenger, 3 Delta, 12 Serpent, 2 Carlsson, 12 Road Ace, 6 Phantom 20, 2 Brem, 2 Mantua and 15 assorted marques of which 83 cars were equipped with differentials. Engines comprised 65 K & B, 39 OPS, 18 OS 21RCABC, 14 Super Tigre, 2 McCoy and 2 Picco.

Fastest Time of the Meeting Ishihara, Japan 20 laps in 7min 21secs. World Champion Phil Booth, GB during the course of the meeting covered 406 laps which represents a distance of 121.8 Km. (76 miles +)

Reception/Press Office with 5 staff permanently on duty dealt with 1500 guests, not counting all the people who asked for passes never mind with what justification (one Frenchman presented his Fishing Permit!). There were 18 requests for time checks of which 5 were justified out of a total of 118 events each involving 8 to 10 runners. Bravo timekeepers — jolly good show!

Protests registered: Nil. Technical objections: Nil. Rules problems: Nil. Organisation problems: Nil. The office sold 400 photographs of drivers, circuit etc.; distributed 10,000 photocopies of assorted result sheets, rules, etc.; made 1200 instant photos for identity passes.

Meanwhile, once again well done everyone: this is a standard for future events that will demand a lot of dedicated effort to maintain.

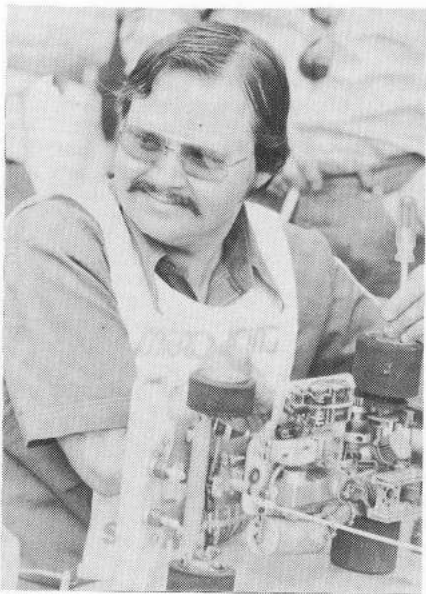

Delta's Art Carbonnel in thoughtful mood.

Naoki Ishihara shows how the divided Tx is worn — here clipped into jeans pocket, sometimes in belt, servo box is hand held.



Mel Braun of South Africa shows his three servo set up with mixture adjustment "on the circuit".

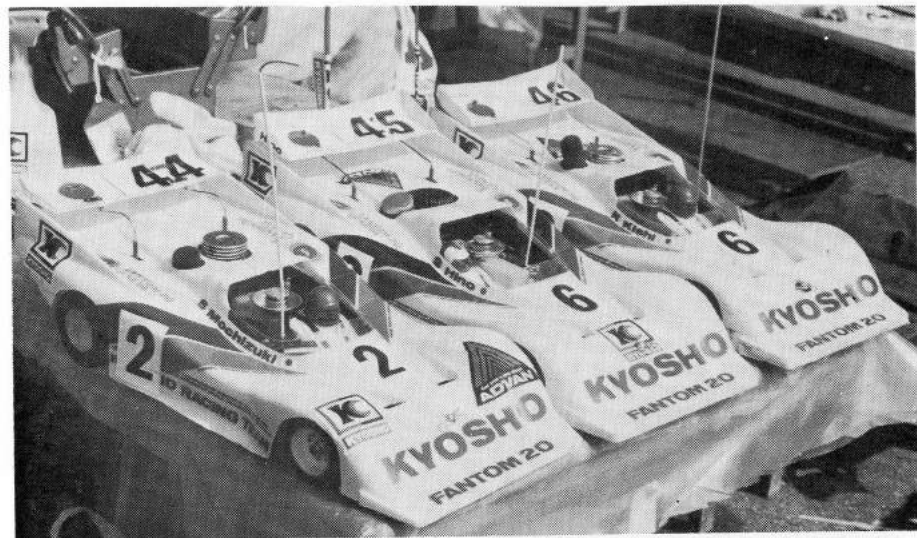

The beautifully painted Fantom 20 Japanese cars, white body colour, black lettering, red sun.

Right: Moment of Truth Phil Booth left has won, Ton and Ishihara move to congratulate him.

Father and son team Pete and Re-Pete Fusco at ease.



WORLD CHAMPIONSHIPS Places 25-72

Place	Name	Country	Car	Engine	Diff	Radio	Lap Time
25	Tassaud D.	B	Serpent	OPS	AMPS	Futaba	20 7.51.839
26	Fruhwrth	A	SG	ST	SG	Futaba	20 7.51.958
27	Mochizuki S.	J	Fantom	OS21	—	Sanwa	20 7.52.890
28	Soderholm O.	S	Chall'r	K&B	—	Futaba	20 7.53.124
29	De Carro P.	S	Chall'r	K&B	—	Futaba	20 7.54.092
30	Auriot J. P.	F	SG	ST	SG	Robbe	20 7.54.527
31	Marzocchi M.	I	Ass'd	K&B	AMPS	Futaba	20 7.55.202
32	Seveso P.	I	Ass'd	Picco	AMPS	Futaba	20 7.56.150
33	Bester W.	ZA	PB	OPS	PB	Futaba	20 7.58.419
34	Muller H. P.	CH	Record	OPS	—	Futaba	20 7.58.889
35	Carbonell A.	USA	Delta	K&B	Delta	Futaba	20 7.59.190
36	Tomita N.	J	Road Ace	OS21	—	Sanwa	20 7.59.374
37	Mizushima N.	J	Road Ace	OS21	—	Sanwa	20 7.59.795
38	Fiocchi	CH	Serpent	K&B	—	Futaba	20 8.01.602
39	Thurkof M.	CH	PB	K&B	—	Futaba	20 8.01.714
40	Rowland M.	USA	Ass'd	K&B	AMPS	Futaba	20 8.02.648
41	Alberti M.	CH	PB	K&B	—	Futaba	20 8.03.450
42	Grunder E.	CH	PB	K&B	—	Futaba	20 8.06.598
43	Vasselli S.	I	SG	ST	SG	Futaba	20 8.06.921
44	Preston Debbie	GB	Ass'd	OPS	AMPS	Futaba	20 8.11.988
45	Gadaleta A.	I	AsSpadaro	ST	AS	Futaba	20 8.12.699
46	Kruhsberg K.	S	PB	K&B	—	OPPS(?)	20 8.13.057
47	Lemaitre J. P.	F	Ass'd	K&B	AMPS	Futaba	20 8.13.419
48	Taki Y.	J	Fantom	OS21	—	Sanwa	20 8.14.423
49	Matrone J.	F	SG	ST	SG	Robbe	20 8.14.797
50	Dosch R.	G	Serpent	OPS	AMPS	Futaba	20 8.14.908
51	Greeno P.	GB	PB	OPS	PB	Futaba	20 8.15.007
52	Wiedler R.	CH	SG	ST	—	Futaba	20 8.16.251
53	Lecat D.	F	Ass'd	OPS	—	Robbe	20 8.16.871
54	Suzuki A.	J	Road Ace	OS21	—	Sanwa	20 8.18.253
55	Shudo H.	J	Fantom	OS21	—	Sanwa	20 8.19.713
56	Codeluppi M.	I	Ass'd	K&B	AMPS	Futaba	20 8.24.000
57	Hanaki H.	J	Road Ace	OS21	—	Sanwa	20 8.24.248
58	Franke U.	CH	SG	Picco	SG	Futaba	20 8.24.265
59	Plested K.	GB	PB	OPS	PB	Futaba	20 8.29.871
60	White S.	GB	Serpent	OPS	AMPS	MacGregor	20 8.30.807
61	Zimmer R.	D	Ass'd	K&B	—	Futaba	20 8.33.258
62	Cromberge F.	NL	Serpent	OPS	Serpent	Robbe	20 8.36.583
63	Giorgetti A.	I	SG	ST	SG	Futaba	20 8.36.929
64	Johansson H.	S	Carlsson	K&B	Carlsson	Futaba	20 8.42.984
65	Heller R.	D	Carrera	K&B	Carrera	Carrera	20 8.49.496
66	Angelin P.	F	PB	OPS	AMPS	Futaba	20 8.54.042
67	Bergdhal J.	S	Carlsson	K&B	Carlsson	Futaba	18 8.39.998
68	Katsura S.	J	Road Ace	OS21	—	Sanwa	17 8.15.236
69	Royet C.	F	PB	OPS	PB	Futaba	17 8.23.510
70	Wipfli H.	CH	Ass'd	K&B	—	Webra	17 8.57.740
71	Blaser H.	CH	Perfect	ACT	—	Simprop	16 6.47.531
72	Ijerman E.	NL	Serpent	OPS	AMPS	Robbe	16 7.03.247

WHAT ABOUT A WHEELIE?

YEARS ago there was an r/c motorcycle at the M.E. Exhibition and the Blue Peter team had an hilarious time with it over a slippery floor on TV — this was i.c. powered and, I think, about one quarter scale. Tech. Editor of our German contemporary *Auto Modell Technik* Heiner Martin produced a Japanese (where else for m/c?) electric r/c in 1/12th scale to enliven the interval at Nuremberg and put it through its paces in masterly fashion. You cannot quite lean it over to footrest scraping angles, but very nearly . . . probably a bit more practice is needed. Drivers were fighting for a go at the Tx and several experts showed their paces or otherwise. Ripmax is currently importing in England (£47.95) as a Suzuki. In USA Kraft have what looks the same under the Honda badge . . . as Dirty Dan Rutherford remarks in *Model Retailer* the Evel Knieval ramp is almost done . . .





Walt Bailey with his Lotus 80 in British Racing Green plus decals. Attractive if not easily "pick-outable" scheme.

Below opposite — another Lotus treatment using PB adhesive stripes.

PART 2
BY
BOB AGNEW,
B.Sc. (Eng)

PAINTING MODEL CAR BODIES

IN THESE articles we have attempted to take a practical approach to the painting of model cars. In this case it means that there are certain key points to remember.

1. Check that the paint to be used is suitable — try this by painting an offcut. Let the paint dry and then bend the offcut to see how well the paint has stuck or if it has made the plastic brittle.

2. Clean the body shell well. This point cannot be stressed too much. It is not good enough just to wash in detergent. You must then be sure that the detergent has not left a film. Wash off well with water and dry. Finally wipe over the whole shell with methanol or methylated spirit and allow to dry.

3. Use a suitable masking tape to mask off the design, paper or polypropylene is best. Vynil gives a good edge but is attacked by paint solvents.

Choosing and designing a colour scheme

Before you start designing a super customised colour scheme just STOP and think for a moment. Most people (even the best drivers!) may have to paint at least four shells a year — perhaps many more. It may be okay to choose a complicated paint job at the beginning of the season before the pressure is on. You won't be happy however if your car breaks down during a mid-season race because you spent the week painting a new shell instead of checking the car. So here are a few ideas.

Firstly before starting take a 'Chinagraph' pencil and draw out your colour scheme on the outside of the body (ABS or Lexan). One of the biggest

problems usually occurs when you come to masking up over curves and details on the body.

Keep the colours to say a maximum of three contrasting colours. A good guide to which colours are striking is to pick colours opposite each other on the colour circle (see fig 1) or in the case of three colours at 120 deg. to each other. Black, white and silver can also work well, with individual colours (usually best results are in pairs black/yellow or bright red and silver etc.) Two shades of the same colour (light and dark blue or red) can look good also.

Choose a simple design incorporating straight lines or blocks of colour. It is surprising how effective a block arrow can look or a patch of colour under the number patch. Shapes like stars or circles can easily be made by using an adhesive label the right size. These can be bought from many stationers. One word of warning when using such labels — after painting and before removing the label score round the outline with a sharp knife to ensure a clean edge. Let the paint dry well and then again clean the unpainted area with methanol to remove any glue before painting the next coat.

If you wish to cut curves or corners. Then first stick the tape onto a glass (preferably) or polished metal sheet and cut the desired shape. Circles and small curves can be made by cutting around a coin. This is particularly useful for headlights etc. The tape is then removed from the glass and applied to the body.

Before starting to paint remember two things.

1. Clean off the shell again with methanol

to remove any finger marks and then 2. With a small nail file, a plastic lollypop stick or similar item rub down the edges of the tape to ensure it seals.

Colours and mixing

One of the easiest ways to give your car a personal touch is to mix your own colours. As you will no doubt appreciate this is a complete subject in itself. We can, however, cover the basics which will enable you to try a fairly large number of combinations.

Paints are usually produced by suspending particles of pigment in a clear lacquer. In paints and dyes almost every colour can be produced by mixing just three primary colours in various proportions. If this sounds too much to take in, just think of all the colours produced by a colour television. Then next time you see one go and have a very close look at the screen. Anyway back to paints. Paint colours work work by absorbing certain frequencies of light. The colour circle (see fig 1.) that is used is therefore produced around the colours known as the subtractive primaries.

This circle is extremely useful for guidance as to which colours to mix to produce any other colour. The quantities to mix have to be found by trial and error but once you know which colours to mix half the battle is won.

Using the circle is quite easy. If for example you wish to make orange; start with the two adjacent primaries red and yellow. It is easier to start by pouring the darker colour into the lighter colour a very

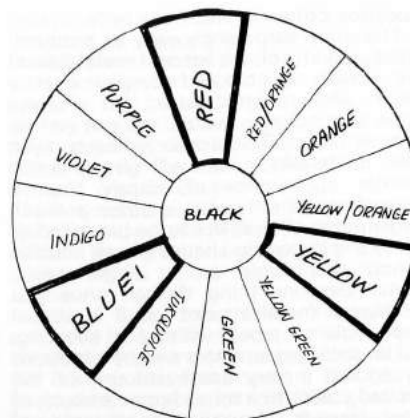
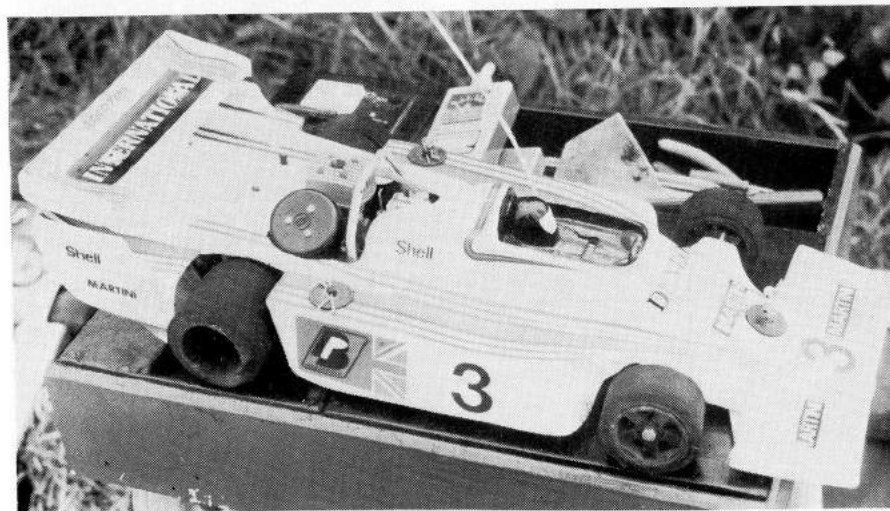

Fig. 1 COLOUR CIRCLE. Subtractive primaries. All colours together make black.

small amount at a time until the desired colour is reached. Adding more of one primary to the mix will swing the mix towards that colour. Adding white makes the colour into a pastel. Adding black will darken the colour but beware it will also tend to make the colour take on a grey dull appearance if you overdo it. If you want to 'brighten' a colour then add a bright yellow but carefully — not too much.

If you are going to make up your own colours make up enough for more than one body and keep them. Matching colours is a very skilled job and you can waste an awful lot of paint trying to match two colours.



Custom colours

These are surprisingly easy to produce. Most custom colours (except metal flakes) are usually a coloured lacquer over a white, silver or gold base. (On a Lexan shell the colours would be put on in reverse order.) The lacquer when sprayed over a metallic colour will give a much greater appearance of 'depth' than a normal metallic. It also enables a much larger range of metallics to be produced as for example certain shades of red metallic cannot be made as a single paint. Remember one thing though once you damage a metallic paint job it is almost impossible to repair without it showing.

The coloured lacquers can be produced by adding a very small amount of the desired colour to a much larger amount of clear lacquer. As a guide a ratio of between 1:20 to 1:10 of colour to lacquer seems to work well. For outside painted jobs spray the base coat (silver etc) first then the lacquer. For Lexan shells spray in the reverse order.

Paint equipment

As most of the problems seem to occur with Lexan type body shells, these will be dealt with in the rest of this article. Painting ABS shells is slightly easier because you are not trying to paint in reverse but the equipment is the same for both.

Probably the cheapest piece of equipment you can use is a good quality paint brush (such as sable). This is perfectly suitable providing certain precautions are taken.

1. Apply the paint very thinly and brush it well out. The danger with paint applied by brush is that it tends to go on too thick and may cause the paint to come off in a shunt.

2. Don't worry about brush marks on

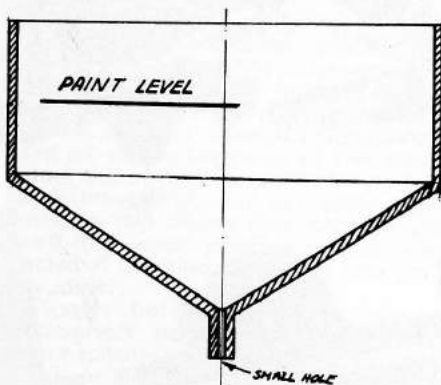

Lexan bodies. Two thin coats brushed at 90 deg. to each other and then backed with white should make any brush marks disappear.

Some finishes such as metallics cannot really be applied by brush. These must be sprayed. A great deal has been written in the past about spray guns so it is unnecessary to go into too great detail. Certain general points should be made, however, as a guide.

1. Cost. This is one of those fields where you get what you pay for. However, before you go out and part with your hard earned savings remember if you buy a large professional gun you will almost certainly require a compressor. All these expenses are okay but how often will you use the equipment. A professional airbrush or small spray gun will no doubt be very versatile and enable you to do many fancy designs (after practice) but a small modellers spray gun or air brush for between £6-£10 will work just as well. Particularly if it is only to be used four or five times a year.

2. Airbrushes — especially the expensive ones are designed in general for detail art work. With most they are even fine enough to write with. Unless you wish to experiment with murals and delicate trick effects a larger spray gun will be of more use. Remember on most car bodies you are spraying largish areas, this can be difficult and tedious if your airbrush only sprays ½" wide bands.

3. Viscosity. No matter how expensive your spray gun, if the paint is too thick it won't spray properly. This is a field in which some professionals have problems. For spraying the paint should have a consistency like water. The most accurate method of testing this is to use a viscosity cup. This is an open plastic cup with a small hole in the bottom. These can often be bought from an industrial paint supplier. You can, of course, also make your own. If you take an empty Fairy liquid bottle and cut the top 3" off it, this will form with the nozzle a useful viscosity cup (fig 2). The way the viscosity is checked is to fill the cup with paint up to a fixed mark and then time in seconds how long the paint takes to run out. The thinner the paint the shorter the time. With the home

Fig. 2 Viscosity Cup. (1) Place finger over drain hole. (2) Fill cup to mark. (3) Remove finger and time how long paint takes to drain out. (4) The thicker the paint the longer the time it takes.

Opposite: Dark contrasting stripes on a light ground simple to paint and distinctive in design.

made cup a certain amount of trial and error will be required initially to establish the correct time for paint to be used in your particular equipment.

Try spraying the paint on a piece of scrap material. If it appears to be a nice fine spray then away you go. If, however, the surface appears to have small 'lumps' of paint, this is known as orange peel and means the paint is not thin enough.

4. No matter whether you are spraying or brushing do so in a well ventilated area. Open a window or two. It is unhealthy to breathe in fumes and it can also slow down the drying of the paint.

DO NOT EVER SMOKE when painting. All paints are flammable.

If you are spraying wear a mask. You can buy throw away masks from a chemist or motor accessory shops.

Painting

At last we are ready to actually spray. (Brushing has already been dealt with).

1. If the body has narrow fins spray these first. Hold the fin open with your fingers and spray into the fin. The paint won't harm your fingers providing you wash it off with a hand cleaner when you have finished. Before you finish you will probably have painted your hands, shirt, trousers and anything else which got in the way! !

Let the fins dry taking care not to let the two sides touch. Then spray a light coat on the edges of the tip. An easy way to achieve a 'dry' or mist coat is to hold the spray gun a little further away than normal from the job. Then spray main coats. A technique used by professional sprayers to prevent build up of paint at the end of each stroke is as follows. Towards the end of each stroke release the trigger (or

button) after you have passed the edge of the area to be painted but before you reach the end of the stroke. Then on the return stroke start moving the gun before pushing the button. This takes a little getting used to but once you get the hang of it you will find it possible to start spraying even in the middle of an area without any build up.

Always start painting the darker colours first. If this does not fit in with your chosen scheme then give the lighter colour a quick coat of white before applying the darker colour.

Do not spray too thickly. You will be surprised how solid colours, which looked almost transparent off the car, look when the body is fitted to the car. The paints must also be applied thinly (this goes for fuel proofer too if used) because the thicker the coat the more likely the paint is to separate from the body should you hit something.

To improve the body of the paint and also brighten the colours it is a good idea to lightly spray over the whole job with white after all the other colours have been sprayed.

Strengthening and repairs

When the shell is dry a thin coat of silicone rubber along the entrance to the fins will keep out any dirt and strengthen the body. A small piece of Lexan can also be glued onto the wheel arches to reduce the chance of cracking. When trimming the shell try not to have any sharp corners from which cracks will start. If a body should crack then (particularly with Lexan) drill a 1/16th" dia hole at the end of the crack before repairing the break. This will stop the small crack developing into a longer tear.

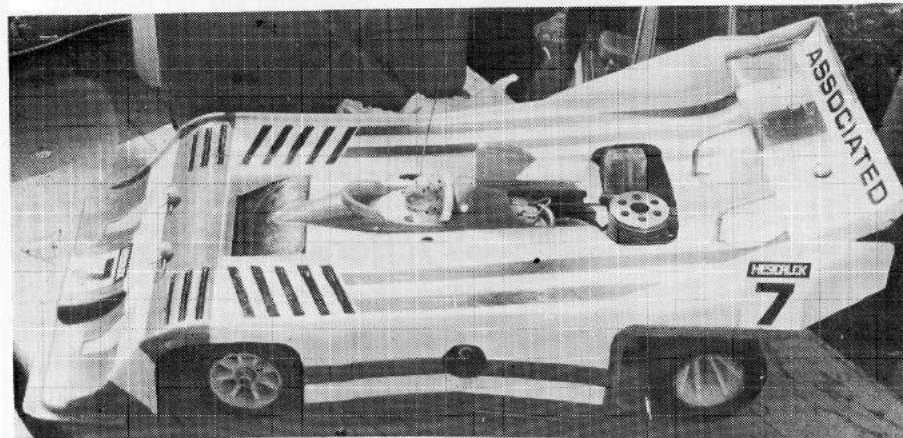



JIM DAVIS MODELS

145 NEWGATE LANE, MANSFIELD. NOTTS.
TEL. MANS. 36062



Congratulations to **PHIL BOOTH** and P.B. Racing Products on winning the 1979 World Championship for G.T. Cars

RADIO OUTFITS

Full range of all popular radio outfits, all at competitive prices. Please ring for full details.

R/C CAR KITS

P.B. International	£79.85
S.G. Futura	£76.70
Associated RC200	£127.75
Mardave	£25.29
Mardave Competition	£30.61
Serpent III	£90.06

100% P.B. and Associated spares and accessories stocked

1/8 SCALE ASSOCIATED LEXAN BODIES

Lotus 79	£7.50
Porsche 917/30KL	£13.84
Elfin Can-AM	£13.84
Porsche 935 Turbo	£13.84
Ligier Maserati	£13.84

1/8 ASSOCIATED TYRES

2402 Ex stock	£4.20
2401 Ex stock	£4.20
835 Ex stock	£3.40
832 Ex stock	£4.36

DELTA TYRES AND ACCESSORIES

Delta 340A	£4.20
Delta 340B	£4.20
Delta Aerials	£2.25
Delta Fuel Filters	£1.60
Delta Servo Savers	£4.86
Delta Servo Arms	£1.32
Delta Linkage Kits	£2.40

LATEST P.B. ACCESSORIES: Light Chassis £10.92, Roll Bar Kit £2.13, Throttle Linkage Kit £2.13, Wing Wire Kit £1.08. Full range of Greeno accessories including **NEW TUNED EXHAUST £16.95.**

A J.D.M. SPECIAL OFFER

ACOMS Two Channel complete for only **£34.95** when purchased with any Tamiya Kit. Suitable for Radio Control. Save over £20.00. Special price also available without kit. Please ring for quote.

BARCLAYCARD, ACCESS OR HOBBYCARD – 24 HOUR MAIL ORDER SERVICE

Hours 9.30 – 6 pm. Except Wed. closed all day

JIM DAVIS R/C RACING

Only 7 miles from M1 junction 27, 28 or 29

R/C CAR ENGINES

Veco 19	£27.65	K & B 21	£42.06
Veco 21	£31.90	O.P. S 21	£52.12
S.T. X21 R.E.	£59.75	Irvine 20 Car	£42.06

PARMA LEXAN BODIES 1/8

Cheetah Sports	£13.84
Shadow Can-AM	£13.84
Lola T333 Can-AM	£13.84
Schee Can-AM	£13.84
B.M.W. 3.5 CSL	£13.84
Shafer Camero	£13.84
Toyota Silhouette	£13.84
Chevrolet Monza	£13.84

1/12 SCALE ELECTRICS

Mardave	£39.93
Lectricar	£49.91
Bolink	£63.84
Associated RC 12E	£63.84
Tamiya Comp Special	£53.19

Full range of 1/12 spares, etc.

SPECIALIST ITEMS

A.M.P.S. Diff for P.B. (Mini)	£35.59
A.M.P.S. Diff Associated (mini)	£36.97
P.B. Differential (new)	£36.20
P.B. Air Filters (new)	£2.92
P.B. G.R.P. Chassis (new)	£8.52
A.M.P.S. Wheels Adaptors for P.B. to fit Thorp or Serpent	
Wheels	£10.11
A.M.P.S. Heavy Duty Servo Arms (pr.)	£1.12
LexanPaint in Aerosols	£2.82
Lexan Paint in Bottles	£1.17
Thorp Wheels (pr.)	£2.34
P.B. Ballraced Disc Caliper	£3.81
Ballraced Servo Tops for 17m	£4.79
J.D.M. Super Soft 1/12 Rear Tyres (pr.)	£1.75
J.D.M. Super Soft 1/12 Front Tyres (pr.)	£1.20

Keith Plested, Managing Director of P. B. Products, Havant, says:

"MacGregor & P. B. Products decided to combine their talents in order to develop a new two channel system for car racing.

The results were most impressive as it allowed an improved driving technique giving a distinct advantage under racing conditions."

A WINNING COMBINATION

The MacGregor MR 1222 ASN/2S special incorporating the new MR 12T high torque servo and the International from P.B. Products.



CONGRATULATIONS TO PAUL PADGIN ON WINNING THE BRITISH NATIONALS WITH THE MR 12 22 ASN/2S

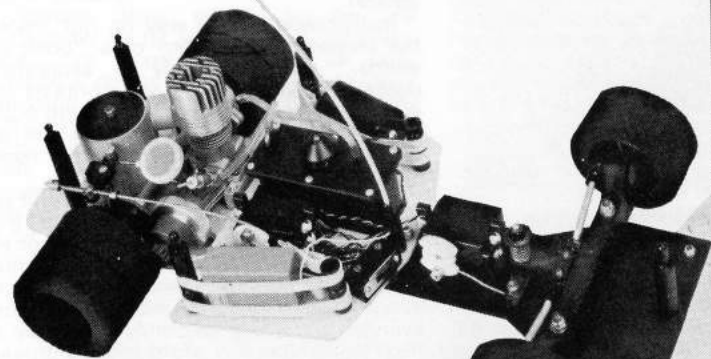

MR 1222 ASN/2S
£99.50

Designed for the improved sensitivity and power necessary for controlling high performance models.

Available in all good model shops now.



MacGregor Radio Control

Canal Estate, Langley, Slough, Berkshire SL3 6EQ
Telephone: Slough 42251

STOP PRESS! To All Retailers: MacGregor are now distributors for P.B. Products



Join SMAE—the modellers safeguard Tel. 0272 48869



PB9 WORLD CHAMPION

me. The same sort of treatment with the other metal parts of the assembly is worthwhile even to rubbing down the thrust washer with emery so that circlip groove is flush with the ballrace. Somewhere in the instructions the master says: "... a degree of engineering skill, together with time and patience will pay dividends in the end. Each part has to have a manufacturing tolerance in production as selective assembly of parts would reflect in a substantial price increase. We therefore ask you to deburr and fit some parts to obtain the ultimate fit." Splendid advice!

Instructions by the way do not follow the conventional pattern of a "book of words." Each assembly is separately packed in plastic bags and contains its own assembly instruction sheet with such pictures as are needed, plus a sheet of general instructions from which I have quoted.

A particular joy of the front axle unit is, as we have remarked before, that the ballraces are fitted to the axle block not to the wheels so are always there and do not necessitate having ballraces galore on every wheel. Once the unit is set up and everything running smoothly it is really a treat to handle. Any slight initial stiffness will disappear when the car has been on the road for a lap or so and these self-aligning bushes settle down.

My stock of goodies from my visit included precision made metal plummer blocks for the differential/axle assembly and this is the only item I have cheated with in putting my PB9 together — they are just much too good to ignore. The kit now contains the long awaited fuel tank which has turned up in white and allows fuel level to be seen. Second thoughts are to retain this colour rather than the fashionable black originally intended. It fits exactly in the two holes already drilled for it on the GRP chassis plate. A very little

Heading: Phil Booth gives his car the last once over before the Final.

Right: The new fuel tank (Phil used a laid-flat Johnson type) and the car again as lent to Ted Longshaw for German G.P.

IT was a very welcome surprise when Keith Plested gave me one of the first off of the latest PB 9 international kits: he had loaded me up so very generously on my visit to Havant that I certainly did not expect it! My friendly neighbour editor Bill Burkinshaw of **RCM & E** got a kit too, and put it together in record time to race at the Bradford Mintex meeting — I must enquire how he fared. It can indeed be put together just like that "It's a doddle! Two evenings and ready to run!" but I like to kid myself that if I do the job slowly and carefully I shall finish up with a much better car. That's the way World Champion Phil Booth operates: I've seen him! Anyway with a nice gift horse-power on my hands I went reckless and acquired an OPS engine to go with it from Tony Mills of Irvine Engines up the road.

A lot has been written about the Ackermann steering built in to the steering gear but far more important is the assembly of the front axle kit. Just like Phil Booth I slip the axles in the lathe chuck and touch them up with a slip of emery paper, using the Unimat lazily sitting down at the table. Phil has a Unimat too he tells

must be rubbed off the side of the adjacent servo mounting bracket to enable both to fit compatibly.

These plus the radio and battery mounting posts are all screwed in place with selftapping screws. Do save yourself effort by fixing them in the vice and screwing through first with a little Vaseline for lubricant. Another little tip from the Champion's car here is to save some weight by using a set of the small nicads rather than a single larger battery. They need a quick charge once or twice during a day's running but save an appreciable amount of weight. One in use and one set on charge may be your passport to an unexpected win.

If you are one of those who like a separate radio plate do not despair. By the time this appears Keith's radio plates, based on a design that was tried and tested for most of the season, should be back from the GRP cutting service and embody some of the latest weight shifting tactics that have proved beneficial on some circuits.

Another slow comer is the PB carburettor so far seen only in prototype form. Phil Booth used one of Dave Preston's design which is very much a precision made job and cost accordingly but worth it. I settled for a Speedmodels slide carb given me at Geneva complete with the now very popular paper concertina would air filter. Design is very like PB's original slide carb but cleaned up a bit and completely dustproof like the Preston type. You may have seen the

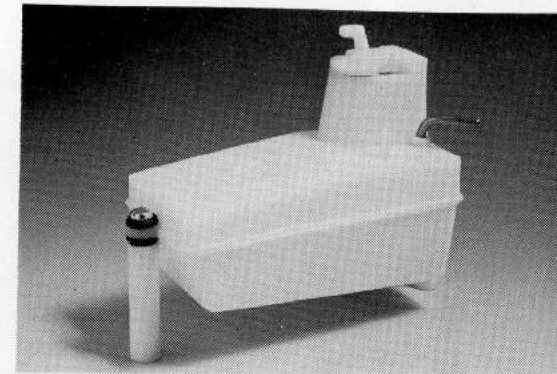

rather odd filter cover on Phil's car — look closely it says '12p off' and comes from some domestic detergent bargain can but it has proved a good luck charm on his car and I don't think he will discard it lightly.

Most of the other bits and pieces have been dealt with in the earlier feature on the PB Visit. There remain the two Lexan bodies provided with the kit. There is no doubt that these are now well up to American standards (I know Phil used the Parma Kroll for Geneva — it is a super design and ideal for the job) and worth the effort of painting up with some of the very varied Lexan paints now on the U.K. market. You take your choice from a range of colours, metallics and fluorescents. Quick tip: You too can go metallic if you add a small amount of silver to a normal colour from the same paint range and mix up well.

Final reminder: Build slow to race fast!

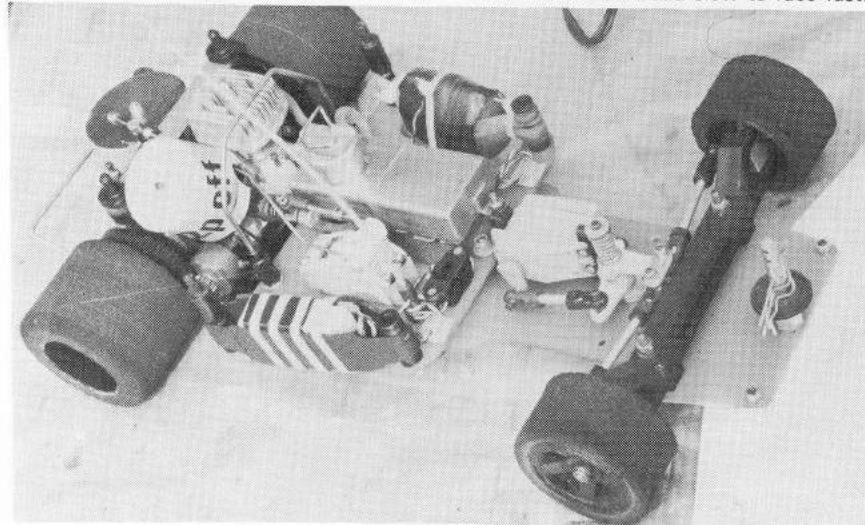

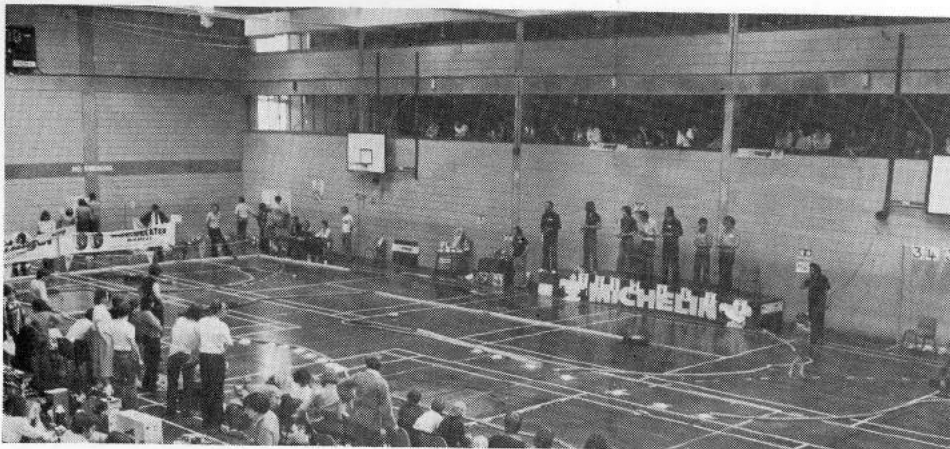

CORGI GRAND PRIX

PHOTOS: JON MOULTON

THE Nene Radio Car Club hosted the Corgi Grand Prix at the Lings Forum, Northampton on Sunday July 1st. A varied programme was organised by the club to include a Corgi Toys display which attracted the children in their droves, an Aurora race circuit & trade exhibits.

Of the eighty pre entries an enthusiastic seventy seven arrived eager to qualify for the twelve car Grand Prix, prizes and trophies. The meeting had been devised on full size G.P. principles by race director Colin Spinner, with a well received lunch break vintage car demo, celebrity saloon race, truck event etc.

Four heats per driver were run with the best three heats totalled to score — Heat 1 also served to determine grid positions for the rest of the day.

The circuit had become very slippery during construction and it became obvious after heat one that the correct tyre mix would reflect in the top

qualifiers of the day. The usual floor markings at Sports Centres were very apparent but drivers quickly adapted to the track.

A separate class for Lady drivers was established as females accounted for ten per cent of the entries — well done girls, but let's see even more of you in the future — driving we mean! An early lead in this class was taken by Wendy Bork of Team Spectron. After forty qualifying heats pole position on the G.P. starting grid went to Neal Francis together with the Modelcraft Fastest lap Trophy. Also to qualify straight into the G.P. were Ken Wright, Bill Maisey and Les Pipe. Two semi finals of eight cars each with the top four from each made up the rest of the grid.

Interval attractions of the celebrity saloon race and the truck event gave the requisite time for

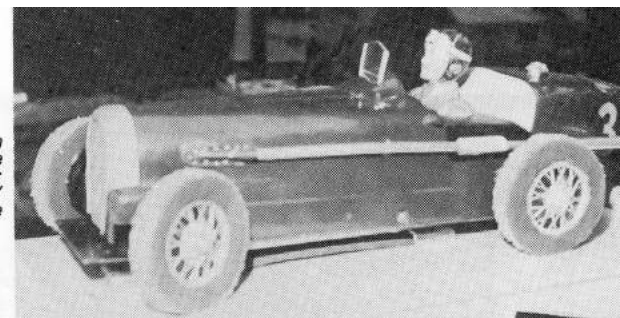
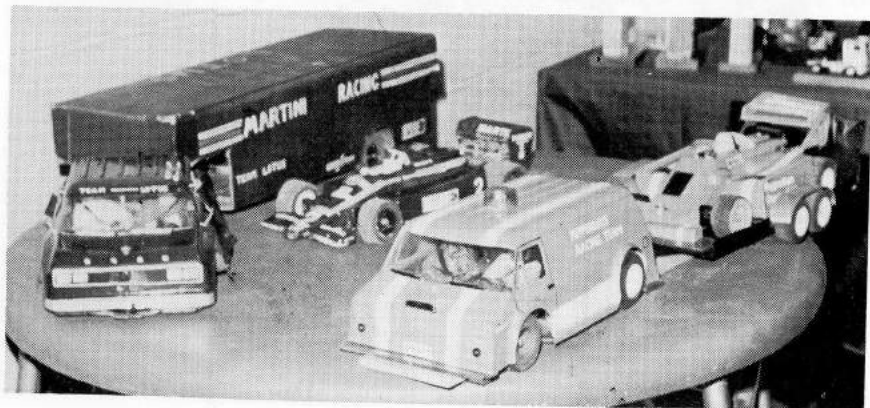

Heading shows the splendid Lings Forum venue. Bottom left are the truck entries — three only in number but high in merit. On right: Growing in popularity is the "Vintage Class" encouraged by the Midland Club. Below: The busiest Pits area I have seen for a long time.

competitors charging. Due to various reasons only three entries appeared for the truck event. Derek Bailey was the class winner with a superb custom van and trailer complete with flashing lights! On the track, however, it was the ingenious articulated Martini Lotus transporter of Tony Devonport that showed at the front. Winner of the celebrity saloon race, Jon Moulton, representing Riko-Tamiya headed home second place man Dave Pepperday of Chesterfield.

By now the customary over run had occurred so the Grand Prix finally got under way around 7.15 without the warm up lap. Absent from the line up was seventh qualifier Dave Hooper of Team Spectron who for some reason had misread the results of the semi finals and had already gone home. Off the staggered grid it was Ken Wright who took an early lead followed by Alan Blakeman, soon to become the unluckiest man of the meeting when his motor seized solid forcing him to retire. Into second place stormed Geoff Peters chased hard by Tony Devonport. On several occasions they banged together-Gilles Villeneuve fashion — after all Tony was driving a Ferrari!, but eventually Geoff pulled away. Bill Maisey moved up into third place when Tony made a mistake. An eventful end to a super day.

A special mention of Concours winner Pete Horne (Lotus 79), Stuart Wilkins (Surtees Ts16) Bill Burkinshaw McClaren M28) and team concours winners Team Wormall.

Wendy Bork maintained her early lead to finish as Ladies Champion.

Jim Davis Models (Neal Francis, Tom Morgan, Wayne Davis) won the team award.

Many thanks to our sponsors Corgi (The Mettoy Co Ltd.), Riko-Tamiya, Modelcraft Blaby, several local companies and members of the Nene Radio Car Club — particularly Tony and Ros Chaplin who spent more than eight hours on the lap-scoring equipment.

Finally to all the competitors, pit crews, spectators and the Northampton Borough Council Leisure Dept. thank you for making the day a success.

Corgi Grand Prix Results

- 1st. Ken Wright. Sheffield. Team Fred Karno.
- 2nd. Geoff Peters. Bedford. Ally Pally.
- 3rd. Bill Maisey. Birmingham. Modelcraft.
- 4th. Tony Devonport. Coventry. Mardave.
- 5th. Neal Francis. Birmingham. Jim Davis Models.
- 6th. Fred Hatfield. Sutton Coldfield. Pearson Diffs.





DONINGTON PARK REPORT BY LES PIPE

I HAVE just returned from a very pleasant day's racing at Donington Park Race Circuit. The theme of the day was an enjoyable day for racers and spectators alike. We were fortunate in having a lovely sunny day which meant that club members brought along their families and this made it a pleasant social event as well. The format of the meeting was simple . . . 5 minutes heats leading towards three finals. The drivers were split into three classes (as is the usual practise at our club meetings) Class A . . . Experts, Class B . . . Amateurs, and Class C . . . Novices.

Racing was continuous from early morning, amongst the tyre screams coming, not from our cars, but from the Triumph T.R.s being thrown about further on up the piece of track we were sharing. We shared the Donington facilities on this day with the Club Triumph Open Day, which boosted our spectator numbers considerably. All the spectators seemed enthusiastic about our racing, all be it on a smaller and much 'tamer' line.

Apart from the normal race meeting, one of the highlights of the day was a session round the full size circuit with our 1/12th scale cars. This took the form of a time and performance trial which proved most interesting. We were lucky enough to be allowed three trips around the circuit. Pete Horne (the chief organiser for the day) had made all the prior arrangement and the six drivers he had chosen walked out to the circuit where a Triumph Princess with a platform on the back provided a good driving position for

the drivers to control their cars from. It was decided that a back-up car was needed to pick up any car that might 'fall by the wayside'. A TR7 was selected for this task and I volunteered my services to accompany the driver (I was determined to get round the circuit somehow!) We managed to clock up a steady 25 m.p.h. following our 1/12th scale cars round the circuit, and a complete lap of the 2 miles plus circuit took approximately 5 minutes.

After our excursion around the full size circuit it was back to some serious racing. Everyone taking part in the driving found it a welcome change to get some traction without having to worry about siliconed tyres. All in all it was a great day's racing. Special thanks must go to Pete Horne and his band of helpers.

*Donington Park provided the right atmosphere for the meeting.
Below: The ladies race attracted a good entry — here they are on the rostrum.*



HOWES MODEL SHOP

9-10 BROAD STREET, OXFORD. TEL: 42407
1/12th ELECTRIC CAR SPECIALIST

DIFFERENTIALS

Schumacher adjustable limited slip differential fits Mardave, Lectricar, Bolin, MRP, Spectron, Associated £6.92. Please state make of car when ordering.

46, 48, 50, 52, 53, 54, 55, tooth gears
£1.06 each
Diff wheels **79p each**
Wheel with grubs **79p each**

ALL SPARES STOCKED

Amps differential with bevel gears for 1/12th Associated **£11.44**

1/12th RADIO TYRES

Extra hard fronts **£1.00**
Hard fronts **79p**
Hard rears **£1.32**
Med/Soft rubber fronts **72p**
Med/soft rubber rears **£1.20**
Med/soft neoprene fronts **£1.17**
Med/soft neoprene rears **£2.00**
Soft neoprene fronts **81p**
Soft neoprene rears **£1.32**

Epoxy glass chassis 7" and 14" **£3.45**
Epoxy glass chassis 3" and 11½" **£1.38**

All 1/16th thick very strong.

American Race Car World bi-monthly magazine/newspaper covers 1/8th and 1/12th R/C Cars **80p** for 1 copy **£4.50** for one year, ie: six copies.

ELECTRIC MOTORS

Mabuchi RS54 **£4.20**
Mabuchi RS54 sprint **£5.50**
Associated 05 **£6.82**
Associated 05 rewound **£9.75**
Cam 05 ballraced with cooling fan **£14.75**

CAMBRIA FRONT WHEEL DRIVE

1/12th Car less Ni-Cads **£36.95**
Ni-Cads for above **£11.18**
Front wheels **30p each**, Rear wheels **40p each**. Set of 4 tyres. Medium **£2.40**. Soft **£2.80**. 14, 16, 17 tooth pinion **£1.15 each**.

GRAUPNER FRONT WHEEL DRIVE 1/12th CAR WITH A DIFFERENTIAL with motor and speed controller **£54.25**

BRITISH LEXAN BODIES

Mazda RX7 **£5.99**
Ferrari 330 p4 **£5.99**
McLaren M8 Cam Am **£5.99**
Lola T70 **£5.99**
Renault Le Mans **£5.99**
Ford Capri **£4.63**

BARCLAYCARD, ACCESS, HOBBYCARD — ALL WELCOME
Orders over £2 post free in U.K.
Under please add 30p

NEW MARDAVE 1/12th ELECTRIC SHOULD NOW BE IN

two of a kind



1/12 SCALE ELECTRIC RACING CARS WITH SENATIONAL FRONT WHEEL DRIVE

Transmitting the power to the front wheels instead of the rear gives better traction and positive steering, eliminating the problem of rear wheel spin off.

All the available power can be used giving higher acceleration and faster cornering for superior all round performance. Each kit contains all parts to build one of these fabulous models to Cambria's normal high standard.

For 2 function radio

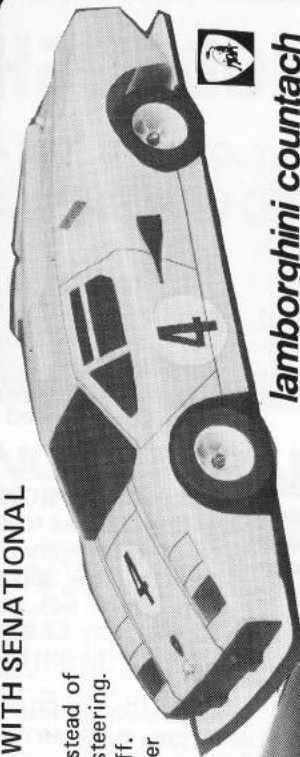

lamborghini countach

Design engineered for superior road holding and performance Full range of accessories for the enthusiast including different grade tyres, sprint motor, choice of gear ratios, front and rear ball race kits, choice of body shells, plus a spare parts service second to none.

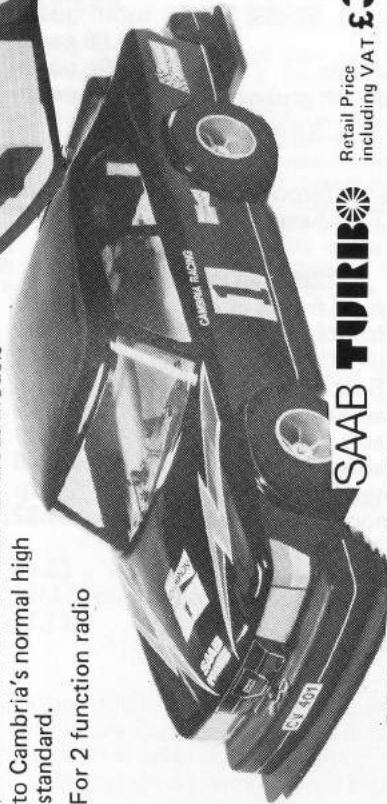

SAAB TURB

Retail Price including VAT. **£36.95** Nicad Battery Pack **£16.00**
Kit complete with batteries **£52.95**

Mid Wales Model Manufacturers Ltd., High Street, Llanidloes, Powys
Distributed in U.K. by Cambria and Ripmax

GB MODELS

R/C CAR DISTRIBUTORS

9 THORNBURY ROAD,
UPHILL,
WESTON-SUPER-MARE,
BS23 4YE.

Tel: 0934 — 26265
24 hour Answering Service
WHEN WE'RE IN BED!

CONGRATULATIONS!

To: World
Sports/GT Champion
PHIL BOOTH
driving a PB9

To: British
Sports/GT Champion
PAUL PADGIN
driving a SERPENT

Full Range of PB Serpent & SG Kits & Parts Ex-Stock

NEW Super Tigre X21 Rear Exhaust Engine **£64.95** complete or **£54.00** (less silencer and manifold)

FULL Range of S.G. FUTURA III Parts Ex Stock. SG 1/12 Car Coming Soon!
BO-LINK BLX 94 1/12th Car **£63.85**; BLX 144 **£60.65** (no speed control). These are ready built cars with painted and trimmed Lexan bodies awaiting your radio and r'aring to win races.

TYRES from PB: RAYDIO: DELTA: UFRA: SG: 1/8th and 1/12th scale.

BODIES from PB: PARMA: BO-LINK: SG **PLUS** THORP: DELTA: McCOY, etc. GOODIES.

LEXAN PAINTS AND ADHESIVES

PAINT FOR MODEL CARS Specially developed for use on the body shells of Model Racing Cars in both 1/8th and 1/12th scales. Features: Wide Range of Standard colours. 10 standard colours red (light), red (dark), yellow, light green, dark green, tangerine, blue (dark), blue (light), white, black. Metallics: silver, gold, bronze, blue, green.

Can be brushed or sprayed, excellent adhesion to Lexan and ABS. Does not embrittle Lexan. All colours are intermixable. **£1.00 per 50ml tin.**

These paints have been produced for easy application on both ABS and Polycarbonate (Lexan) body shells. It can be brushed straight from the can or by thinning up to 50% with a special thinners (special thinners required). **£1.33 per 125ml tin.**

RUBBING PAD Aluminium Oxide impregnated plastic PAD. Ideal for flattening off any model or paint surface prior to painting. Super fine or medium grades available (medium approx. equivalent to 1200 grade 'Wet or Dry' paper). **90p per pad.**

NO BLEED MASKING TAPE. A very special masking tape made from plastic. This tape can be stretched to conform to double curvatures or to produce smooth curves. Produces a sharp paint line. 10 metre rolls, **6mm wide 89p, 12mm wide 99p, 25mm wide £1.40.**

LEXAN ADHESIVE. Solvent bonds Lexan to Lexan permanently without making the Lexan brittle. 93p per 30ml tin.

Paint available in 50ml tins sufficient for approx. 2-3 body shells. Thinners in 125ml easy pour tins

SHOPPING AROUND

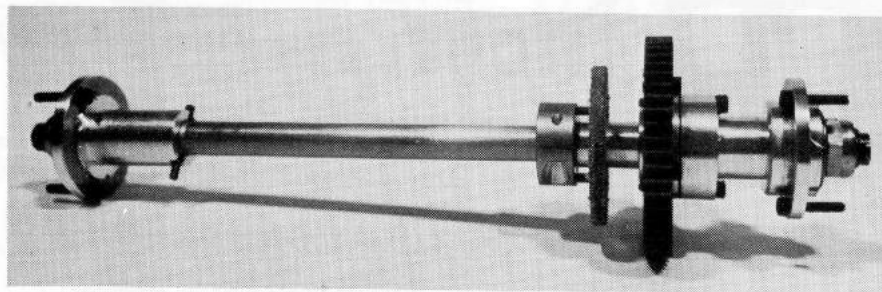

HOT after its first appearance at Geneva Delta have released their limited slip differential that Art Carbonnel was running there. It does not use gears but steel balls and steel thrust bearings, with torque transferred by friction between balls and thrust washers. Friction is produced by preloading the washers against the balls and is adjustable. I do hope I've got it right. Meanwhile the AMPS people are producing a diff. for virtually every leading make of car and have now turned their hand to a 1/12th scale diff. for electrics selling at under £10. I have not seen it to try yet — but doubtless soon will . . . they even have a version to install in the Cambria FWD Saab on the stocks.

Another interesting little novelty is a 1/8th scale Graupner r/c car fitted up for electric drive using their inline set-up to drive the car via annular ring and planetary gear. I do not know whether this

foreshadows a new development: it is very different from their 1979 Toy Fair prototype.

Everybody has had a go at tuned pipes for exhausts, mostly now the answer is a short pipe that tucks into the dustbin or sugar bowl type of silencer. PB were first off the mark with their insert that reduces noise quite considerably if strict attention to fitting instructions is paid. The type used on their championship team cars is not exactly like that but may be marketed in due course. Phil Greeno has a new style silencer with entrance to the can at the top, an internal baffle, and an exit at the bottom which seems to perform very well (he managed all right in Belgium the other week!) Those who have stuck to the long pipe without trying to turn it into a corkscrew will like the Finnish product offered Racing Hobby (PO BOX 130,00151 Helsinki 15, Finland) Makers claim no

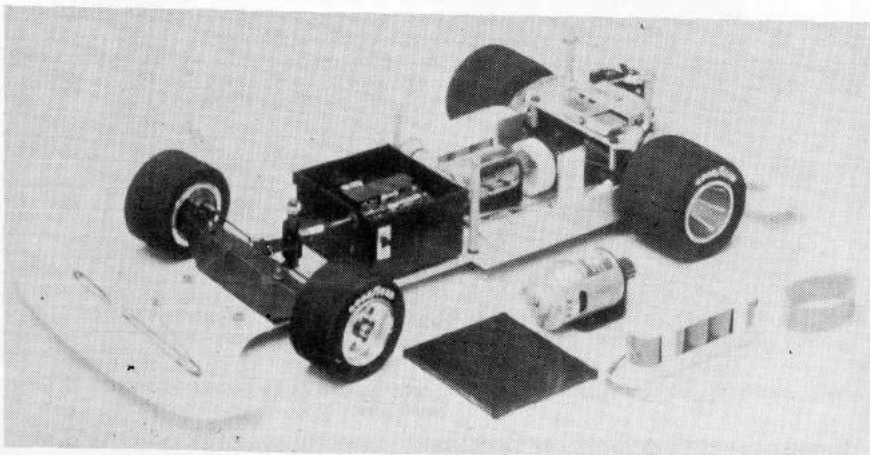

sudden burst of power but a soft transition within the power band, sound level below 80db and a simple mounting to go under the lowest of sports bodies and safe outlet behind front wheel.

PB Racing Products have got out a splendid line in decals. These are the self adhesive type printed in multi-colours on transparent film. The whole sheet was so enormous that Keith decided to have it cut into five pieces for ease of handling and you can have a set for £4.50. If you think you will never use up that many share with a friend or buy some at club level. It includes sizes that will suit both 1/8th and 1/12th scale cars and has 1/8th size numerals for racing numbers.

Another goodie from the PB stable is a super high speed ball bearing on the lines of the McCoy 60 thou. rpm bearing but selling a little cheaper. The PB fuel tank has arrived on the market too, and looks good complete with flip-top. It fits the designed holes on the International GRP chassis plate. On the subject of GRP plates PB have a radio plate in the offing (may be ready by now) which was extensively tried out during the summer and will be welcomed by those who prefer a plate to radio posts.

Walt Bailey has been trying out the Webra 3.5 RC engine for Jack Williams of Model Rectifier UK Ltd who is main importer of the whole Webra range. With a little skilled attention, such as opening out the housing to take an OPS slide carb it performed on the bench only a few 100rpm behind the OPS and then showed splendid pace on the track at Tibshelf. In a friendly run with Dave Preston and Phil

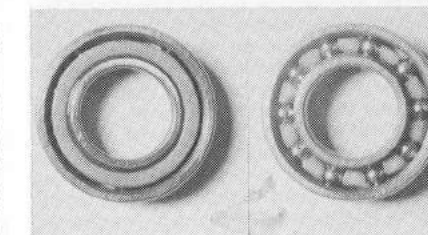
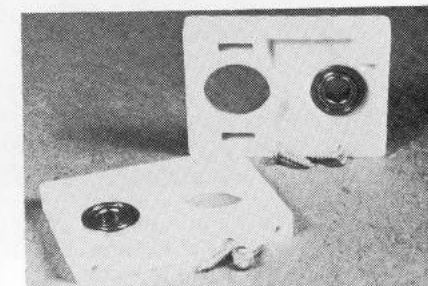
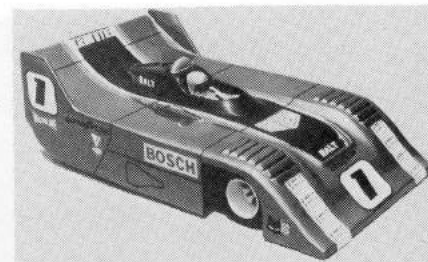

The Delta limited slip differential, first seen at Geneva.

The Graupner R-C Car with a difference: all there but electric powered . . . is this a new thought of theirs?

Ralt Can-Am 1/12th body of Parma, clear or painted in Lexan — looks a real winner.

Nice BB blocks for 1/12th electric from new people Alpha.

Latest PB offering is their super high speed ball bearing, show back and front; and finally the PB self adhesive decal bundle.

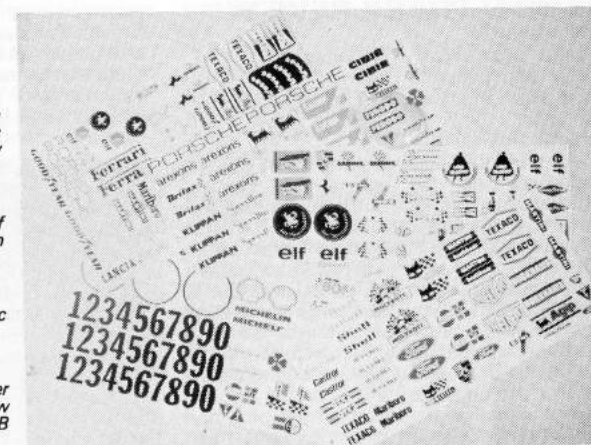

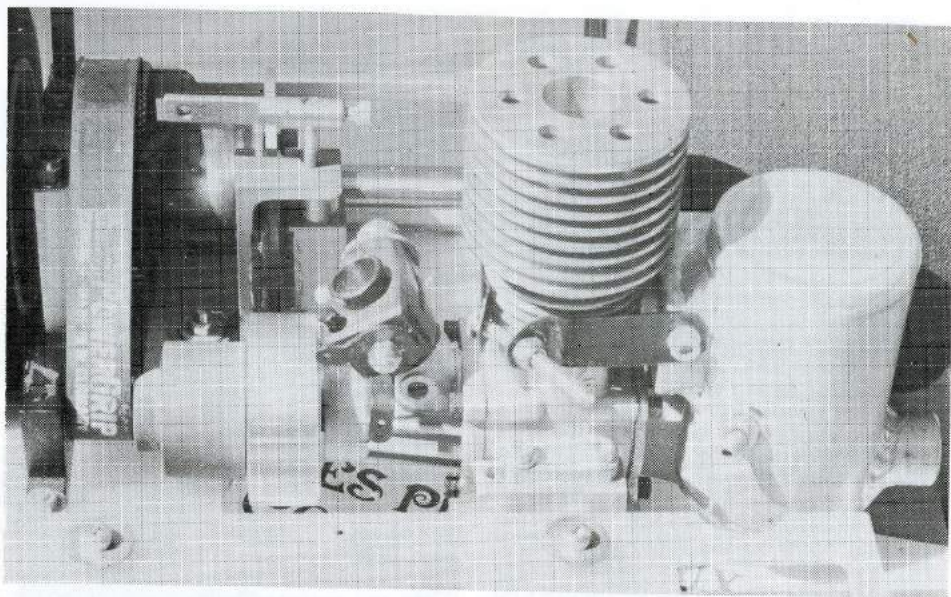

Booth, running OPS cars it was able to hold them without great difficulty. Just a little bit less torque on the lower end but otherwise great. Jack has sent recommendations to the makers and hopes a slightly amended version may be on offer over here soon. I see that Robbe in Germany is promoting the Enya 21 X RC with a claimed speed range of 3/24000 rpm, schnuerle porting, ABC... it would be nice to have one over here. Meanwhile we await stocks of the real OS21 RC ABC engine from Japan.

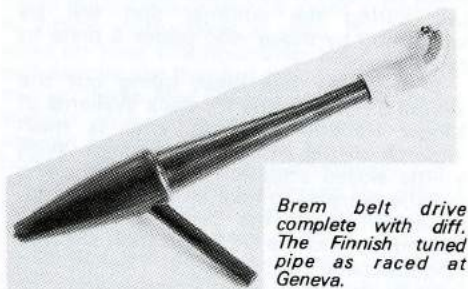

Brem belt drive complete with diff. The Finnish tuned pipe as raced at Geneva.

CLUB & TRACK REVIEW

(from page 6)

Radio Stock Car Leicester

Secretary: Stewart Busby,
72 Rosamund Avenue (Tel: 898683)
Leicester
Braunstone

Membership currently stands at 65 with members as far away as Lincoln, Nottingham and Coventry and represents nearly a quarter of the total RSCA membership — all members being members also of the parent association. Usual meeting turnout is around 30/40 drivers. Most of the meetings have been sponsored so the club has got off to a good financial start. The meeting at Batchelor Bowles Garage produced nearly £30 for the Lord Mayor's Scanner Appeal, being collection from the crowd plus half the entry fees. Away meetings have been

attended with Bob Clayfield winning at Crystal Palace, Ivan Congrieve at Keighley and Steve Talbot twice at Coventry. Bob Clayfield can also supply chromed pistons and liners for Veco and Fuji engines at £5 on exchange basis. Apply at 9. Hall Road Burbage, Hinckley (Tel Hinckley 36473).

Nene Radio Car Club

Secretary: Colin Spinner
52 St John's Avenue
Northampton (Tel: 844943)

Scene of a recent open meeting reported in this issue the club normally meets on Friday evenings at 8.0 pm at Abington Vale School. A search is in progress for larger premises to accommodate the growing number of competitors. Contact secretary for membership details or phone Cecil Schumacher (the differential man!) at Northampton 842320.

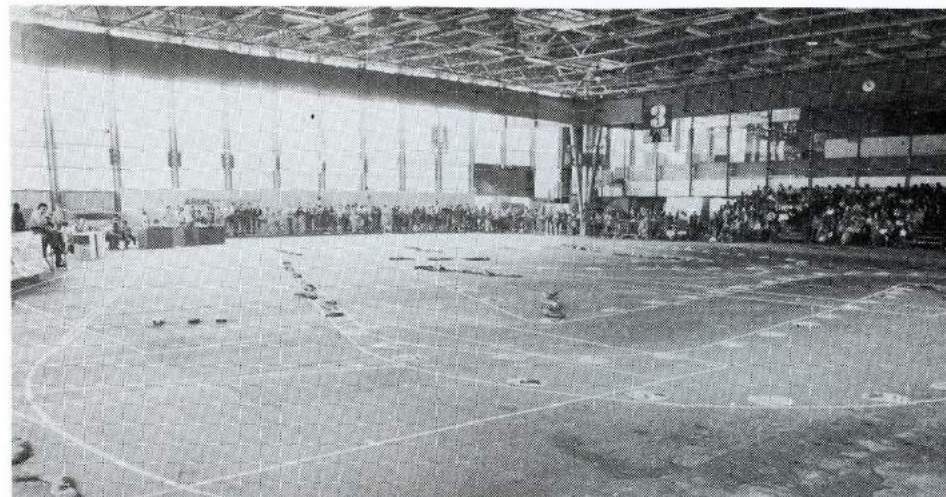

FRENCH CHAMPS 1/12 ELECTRIC

REPORT BY DENIS POULAIN

THE year 1979 has seen an evergrowing interest in electric cars. This is specially so in the Paris district, where for ecological reasons (noise mainly) 1/8 scale i.c. cars are not possible. Electric circuits are numerous, and the highlight of the season was undoubtedly the Championship of France which took place in Grenoble (near Lyons) organised by a group of local model shops.

The Circuit

A splendid hall had been put at the disposition of RAGG (the Grenoble model club) to lay out the circuit. The design of this followed very closely the layout of the American Pomona track. Marking out was effected with metal cones very effectively. Drivers pits were numerous, and each entrant had a table provided for his gear.

Rules

Cars: Two classes were run — but not together. **Production Cars** were not permitted ball bearings. Motor had to be unmodified Mabuchi RS 540 or equivalent. American motors 05 (balanced and epoxied) were legal. **Modified Cars** were allowed ball bearings and modified motors. Six cells — Nicads 1.2v and 1.2 am.

Running: Same system for both classes. Each driver had two qualifying heats of eight minutes each the better time of which counted. The eight best times went forward into a single final also of eight minutes.

Production Car Race

There were no problems for FRAISSE who made best qualifying time and easily won the final. Second was POULAIN ahead of DESARMENIEN. Winners car was a Jerobee with epoxy chassis and Schumacher differential. Radio was Robbe (Futaba in England) and body a Jerobee Schkee.

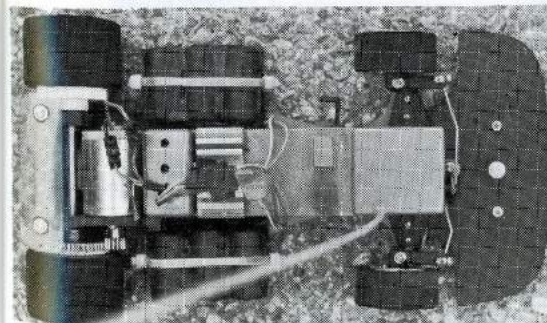

Magnificent hall dwarfs the spectators. Left: Dognon's Modified class winner.



The Jerobee Team — the big winners at the meeting.

Modified Cars Race

Victory went to one of the best 1/8th r/c drivers G. DOGNON who usually drives an SG for the Team Robbe France. But just for the nonce he was driving a Jerobee. This had integral rx, electronic speed control. Chassis was epoxy and a differential was fitted. POULAIN was 2nd and upheld the honour of Associated. Note that the three leading cars finished on the same lap. The struggle for top places was hot.

PRODUCTION CARS

1	Fraise	Epenay	Jerobee	Mardave diff	22	8'	22"
2	Poulain	Montereau	Associated	Porsche 936 GILS	21	8'	12"
3	Desarmenien	Dijon	Associated		20	8'	4"
4	Dognon	Grenoble	Robbe		20	8'	14"
5	Decamp	Paris	Jerobee	Mardave Diff	20	8'	24"
6	Bellenger	Paris	Jerobee	Team B.R.C.	20	8'	26"
7	Collas	Chatelrault	Associated	Porsche 936 GILS	19	8'	
8	Pouvreau	Grenoble	Mardave		19	8'	28"

MODIFIED CARS

1	Dognon	Grenoble	Jerobee	Mardave diff	22	8'	6"
2	Poulain	Montereau	Associated	Porsche 936 GILS	22	8'	19"
3	Fraise	Epina	Jerobee	Mardave diff	22	8'	22"
4	Desarmenien	Dijon	Associated		21	8'	5"
5	Collas	Chatelrault	Associated	Associated	21	8'	17"
6	Bellenger	Paris	Jerobee	Team B.R.C.	21	8'	18"
7	Faupin	Paris	Jerobee	Porsche 936 GILS	19	8'	
8	Desq	Epina	Bohdanowicz Special	Porsche 936 GILS	3	8'	

(Ed. Note **eight minute** heats and finals! This is also apparently quite normal in U.S.A. How many clubs are doing it in GB?)

Conclusion

Splendid prizes rewarded the victors, six complete electric cars plus a number of other items. Organisation was perfect. Spectators were there in large numbers and enjoyed the show. We hope to see in 1980 international events for electric cars . . . why not consider a Championship of Europe next year?

Spectron

Range of Bodies: Lola, Abarth, Alfa, Corvette, TR7, Schkee, Lotus Esprit

N.B. The Mark II Smooth-Tronic is available as a separate item, retail £29.95 inc. VAT.

Better Model Shops stock a complete line of Spectron spares. If not, contact us direct for queries and spares.

THE FASTEST STANDARD PRODUCTION 1/12 SCALE RACING CAR

TEAM TROPHIES

include 1st at Bradford, 1st at Leicester, 2nd at Exeter, 1st at Lilford Park Endurance Race (30 lap clear winners), 1st and 3rd Individual at Lilford Park, 1st and 2nd Battersea Park, Ladies Champion Individual Northampton, 1st City of London GP, 1st and 4th Individual.

Trade Enquiries Welcomed!

L. & D. ELECTRONIC Co. 25 Chartfield Avenue, Putney, LONDON SW15 — 01-788-9711

PRICE: £69.52 (£79.95 inc. VAT)

Kit includes all superlative Spectron features (including Smooth-Tronic, Mark II speed controller and 2-colour Polycarbonate Body).

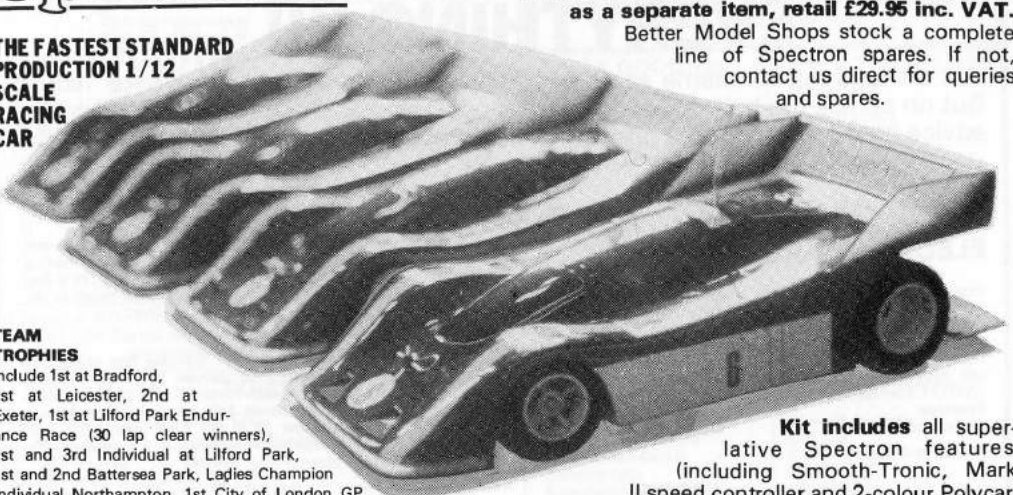

Sent direct by Easibind Allow 2/3 weeks for delivery

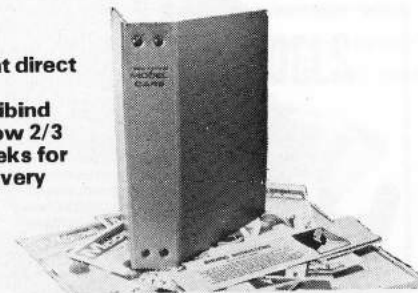

WHAT A BIND!

Elegant BINDERS to make approximately ten copies of RADIO CONTROL MODEL CARS now ready. Covered in Red Balacron (a leather-like material) with "gold" colour title blocked on spine they have the famous Easibind system of holding copies without damage and permitting easy removal. Price includes postage, packing and VAT.

£2.75 HOME

£3.25 OVERSEAS

L-D Editorial & Technical Services Ltd
PO Box 30
Hemel Hempstead, Herts.

SUBSCRIPTION ORDER FORM

I hope you will be able to persuade your local model shop to carry supplies of RADIO CONTROL MODEL CARS: but, if not, I shall be delighted to supply monthly on request or enrol you for an annual subscription, that is six copies a year.

RADIO CONTROL MODEL CARS appears approximately every other month — September : November : January : March : May : July. Six Issues £3.75.

Fill in coupon below (or use plain paper if you do not wish to cut magazine).

Name
(Block Letters Please)

Address

Post Code
(PO/Cheque/IMO £3.75 herewith)

Starting with Issue No.
SUBSCRIPTION ACKNOWLEDGMENT will be included with your first subscription issue. Renewal reminder will come with last issue.

Send to: L-D EDITORIAL & TECHNICAL SERVICES LTD., Post Office Box No 30, HEMEL HEMPSTEAD HERTS. HP1 1NL.

Reg. Office 17 Vicarage Close, Hemel Hempstead.
Reg. England 1291923

WE DON'T STOCK EVERYTHING !!!!

But can still put to shame some of the "largest stocks seen anywhere" sorry! But no across the board discounts from us. Our policy of a fair price and sound advice backed by the best after sales has proved a winner. MRM like Kawasaki rules OK!

SPECTRON ELECTRIC CARS

How boring!! Don't they do anything else but win? John Chamberlain of Maidenhead cops for the 7 day holiday at the city of London, thingummy (jammy beggar) a first in the team race as well with MRM cruising in third still proving that Flexichrome paint holds bodies together.

Spectron underpriced at **£79.95**

All spares in stock

Smoothtronics **£29.95**

Are you prepared for Flexichrome? Then don't bother, 'cos it goes straight onto virgin Lexan and will not flake off. It should be sprayed so it comes in air-brush jars. This in cellulose and covers 3 to 4 1/12 scale bodies

Humbrol 1/2 oz 65p

Badger 3/4 oz 85p

CAMBRIA F.W.D.

Being assembled for a good thrashing when this drive was written . . . by the time you are reading it there will lots of them at £54 each. (Or '79 V Reg Saab Turbo one careful owner, never raced or rallied . . . honest guv'nor!)

Saft Nicads 1.2A. Yes! Genuine first grade cells with original printed sleeves. No military rejects here £2.15 ea. Lexan Plate 12" x 6" £2.00 ea. MRM 1/12 Epoxy Chassis fully shaped, takes Nicads, includes straps £6.75 ea. Clear heatshrink tube neatly encapsulates Nicads into a rigid pack. 60p metre.

55 QUEEN STREET, MAIDENHEAD BERKS
TEL 37295 - CLOSED THURSDAYS.

MAIDENHEAD R/C MODELS

SUPER Tigre

THE NAME THAT STANDS FOR SPEED AND POWER

Guilio Ghersi, Italy, wins Euro. Champs Sports/GT with Super Tigre X21 RE

Since the arrival of the original X21 car over two years ago, it has established itself as a motor of tremendous reliability and low rate of wear under the most arduous conditions. This rugged construction has meant that it has not always been quite so fast as the opposition. Now the time has come for a dramatic change with the introduction of the X21 RE a full Schnuerle port motor with SuperTigre's own blend of directional transfer ports.

This new motor has been expressly designed for car use right from the outset, able to withstand the extreme stresses imposed by the very high rpms experienced. The big end of the con rod is 50 per cent larger than before and, of course, is bronze bushed. The extra large diameter carburettor the same bore size as out earlier 60s and yet retains the easy adjustments for which MAG carburettors are known. The motor comes complete with heat sink head and air filter as standard.

These motors have been developed by leading drivers all over Europe; all that is needed now is Britain's expertise in driving to reign supreme at the world's leading events.

Like all SuperTigres when the edge is off its performance the easy availability of spares and the No Labour Charges on all repairs make this the popular choice.

£56.11 inc VAT complete with heatsink and air filter



SUPER TIGRE MOTORS ARE AVAILABLE FROM THE VERY BEST MODEL SHOPS

WORLD ENGINES LTD

97 Tudor Avenue, Watford, Herts. Phone Watford 42859

Visitors by Appointment

S.A.E. with enquiries please

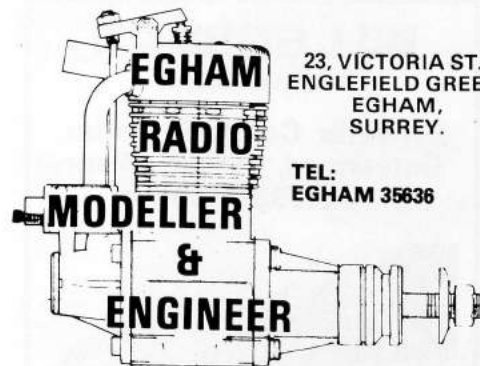

23, VICTORIA ST.,
ENGLEFIELD GREEN,
EGHAM,
SURREY.

TEL:
EGHAM 35636

Full Range of P.B. International and Associated car spares - special fuel mixed with Castrol 98 Gas Turbine Oil - Associated Disc Brake conversion for P.B. International

TYRES		
P.B.	DELTA	ASSOCIATED
371, 372, 373,	340 A & B rears	832, 1223, 1225,
542, 543 fronts	316 & 315 fronts	1226 fronts
374, 540, 541 rears	ULTIMARA	2402, 2401 rears
UFRA	RSS 50 & 60	UFRA
Yellow fronts	rears	Slix & Specials rears

ACCESS, BARCLAYCARD
CHEQUES, EVEN CASH!

* EASY PARKING *

SPECIALS - K & B 21, P.B. Head, PERRY 61 Pumper - Amps diffs, ready to go for P.B. International - New AMPS Mini Diff - Parma March Bodies

DELTA GOODIES

Tank Quickfill Tops
Super Servo Arms
Override Kit
Sintered Fuel Filter
Servo Saver

P.B. HEATSINK HEADS K & B - S.T. - VECO - VECOY BODIES

ABS, Lexan
Lexan Paint & Glue

TANKS

Johnson Metal Tanks
Associated Fillers & Pressure caps
Associated Flip Tops
Big Shot Fuel Bulbs
Sullivan Crap Traps

K & B 21 & S.T. X21 SPARES

Piston & Liners
Conn Rods
Crankcases
Servo Saver
Bearings (welded cage type)

VECO-McCOY SPARES

Rings
Piston & Liners
Heads
Crankcases
Rods

CARBURETTORS

Perry 61 Pumper
E.D. Car
E.D. 60 Size
Thorp Slide
Webra Slide
O.P.S. Slide
P.B. Slide?

OPEN MONDAY-SATURDAY (9.30 - 6.00)
LATE NIGHTS MONDAY & FRIDAY (8.00)

MICHAEL'S MODELS

646-648 HIGH ROAD
N. FINCHLEY N12 0NL
TELEPHONE 01-445-6531

ELECTRIC CARS

Tamiya XR311 Combat Vehicle R/C	£46.50
Tamiya Cheetah Vehicle R/C	£52.00
Tamiya 1/12th Porsche 936 R/C	£39.00
Elec Peanut's Buggy Kit R/C	£44.46
Associated 3010 1/12th Kit	£63.84
Associated 3000 1/12th Kit	£30.83
Mardave 1/12th Electric Kit	£39.94
Spectron with Speed Controller	£81.77

We stock spares, fast charge cells - chargers

CAR ENGINES

Veco 19 R/C	£28.22	Veco 21 R/C	£31.90
STX 21 RE	£59.75	Irvine 20 R/C	£42.07
OPS21 R/C	£52.13	KB21 R/C	£50.59

Phone your credit card number for same day service, Access, Barclaycard, Carte Bleu, Eurocard, Mastercharge, Visa, Bank America Card.

THE MODEL AIR-PORT FILTON BRISTOL

R/C CARS ENGINES RADIO

MAIL ORDER ACCESS BARCLAYCARD HOBBYCARD

EXIT 16 - M5 Five Minutes
Closed Wednesday

134 GLOUCESTER ROAD NORTH
FILTON, BRISTOL TEL: 694541

RACE CAR NEWS from AROUND THE WORLD . . .

WRITTEN AND EDITED BY THE MOST
KNOWLEDGEABLE MODEL AUTOMO-
TIVE WRITERS. COVERING 1/8 and
1/12 GAS & ELECTRIC RACING CARS

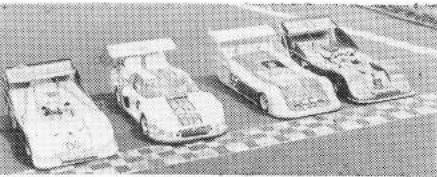

DON'T MISS AN ISSUE,
ORDER YOUR SUBSCRIPTION
NOW . . .

PUBLISHED 6 TIMES PER
YEAR, ONLY \$6.50 ANNUALLY.

RACE CAR WORLD
P.O. BOX 11247, RENO, NV 89520

RACING/ CIRCUITS

LEADING JOURNAL OF RADIO
CONTROLLED AUTO RACING
IN USA

SUBSCRIPTION RATES

\$6.00 **First Class, in U.S.
Canada and Mexico.**

\$10.00 **Air Mail to all
(£5.50) Overseas Areas**

R/C RACING/CIRCUITS
289 Quincy Place
Langhorne/RD 1/Pa/19047 USA

Name _____

Address _____

BILL GORDON (MODELS)

2 Tower Court, Dunston,
Gateshead, Tyne & Wear.
Tel: (0632) 605545

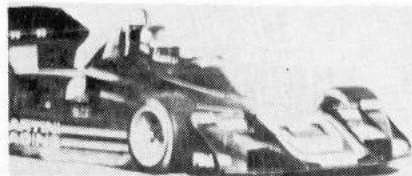

MARDAVE : P.B. : ASSOCIATED : S.G.
LECTRICAR

THE NORTH EAST RADIO CONTROL CAR CENTRE

Mon. to Sat. 9 to 5.30 except Wed.-closed. Late night
Thurs.-7.00 p.m.

We are looking for German
speaking freelancers working as a
permanent foreign correspondent
for our trade-paper

"MODELL-CONSTRUCTION"

We are mainly interested in
reports concerning competition,
developments and brand new
products, tests about rc and
electronics as well as technics,
etc.

Please contact our editorial
house under reference number
RCMC/13/1 to: Verlag fur
Technik und Handwerk GmbH,
Postfach 1128 7570 BADEN-
BADEN, West Germany.

PHIL GREENO MODELS LIMITED
9 VILLAGE WAY EAST, RAYNERS LANE,
HARROW, MIDDX.

5ml
tin
£1



New Supa Car PAINT

Ideal for 1/8th and 1/12th
car bodies. Specially
formulated for Lexan
and Polycarbonate body-
shells. Designed for
spraying - two light
coats suffice, back up
with white for brilliance.

Eight colours: intermixable, Dark Blue, Light Blue, Yellow, White,
Orange, Red, Green, Black.

*NEW METALLICS 5 colours: Gold, Bronze, Silver, Green and
Blue £1.10 Tin.

*NEW FLUORESCENT 5 colours: Pink, Red, Orange, Yellow and
Green £1.00 Tin

Also Fast drying thinners 72p Tin

Fast Mail Order Service Trade Enquiries Welcome

Alpha Track Parts

THE FIRST NAME IN ACCESSORIES

*NEW - INJECTION MOULDED BALLRACED AXLE BLOCKS FOR 8 CARS

- *LOWER CENTRE OF GRAVITY
- *WIDEST CHOICE OF GEAR RATIOS
- *REVERSIBLE - FOR BEST MOTOR ROTATION
- *SUITABLE FOR MOST CARS

*TRADE ENQUIRIES WELCOME

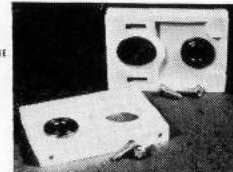

- *1/2" SCALE BODY SHELLS
- *FERRARI 312 SPORTS
- *FERRARI 312 GT - WITH SCREEN AND DRIVER
- *LOTUS SALOON - WITH SCREEN
- *PENSKE - U.S.A.C. FORMULA

*NEW - MARCH SPORTS *NEW - RENAULT LE MANS G.T.

AVAILABLE IN A.B.S. PLASTIC

OTHER SPECIALIST ITEMS ON APPLICATION

Alpha -tel. 0533 898528

MODEL CRAFT
5 CROSS STREET, BLABY
LEICESTER, ENGLAND
Tel: 0533771397



Flexi Wire, Red and Black	10p per ft.
Printed Circuit Aerial	70p
Driver	£1.16
Pk. of Swing Keepers	31p
Ball Links (pair)	48p
Circlip Kingpins (pair)	28p
Quick Change Front Stub Axles with Nuts (pair)	42p

Front Wheels	each 37p
Rear Wheels	each 68p
Set of 4 Tyres	£1.80
Maserati Body	£2.01
Bugatti Body	£2.68
Alloy Chassis	£1.00
Fibreless Chassis	£1.80
Engine Mounts	74p
Axle Beam	74p
Track Rod	74p
Bellcrank	21p
Cyclone Type Motor	£3.17
Motor Capacitor (Polyester)	36p
Motor Pinion	80p
Shaker Plate	60p
1.2 amp hour Ni-Cads set of 4	£8.80

SPECIAL OFFER

Tamiya X.R.311 Jeep, complete
with ACOMS 2-channel radio
control

£69.00

Postage and
Insurance £1.25

POSTAGE: Parts 50p

JUST PHONE YOUR NUMBER

1/12th VINTAGE CAR PARTS

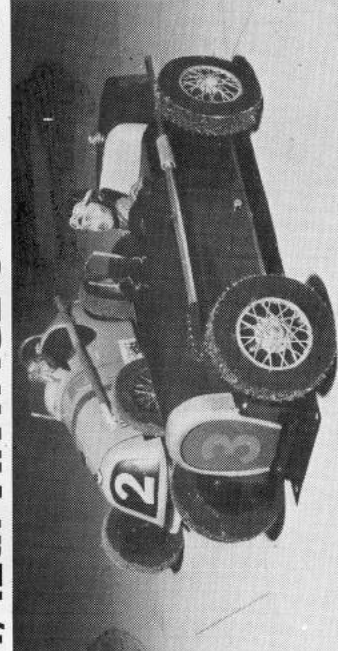



PB racing products Ltd.





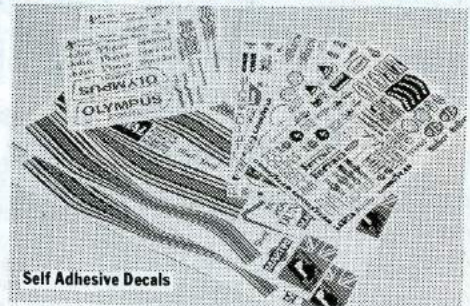



1979 WORLD CHAMPIONS

TO COMPLEMENT THE MOST SUCCESSFUL MODEL RACING CAR YET PRODUCED, WE HAVE AN EVER INCREASING RANGE OF ACCESSORIES TO IMPROVE PERFORMANCE APPEARANCE RELIABILITY AND CONVENIENCE

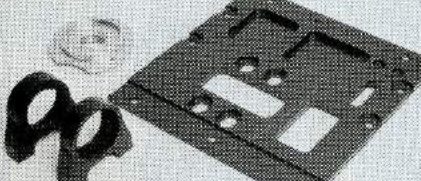
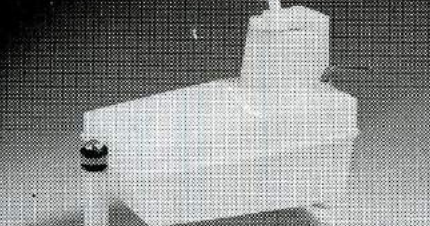

Self Adhesive Decals

Lotus 79 - Gold - 21/241 **£1.04**
 Sponsors - 5 Sheet Set - 21/251 **£4.50**
 Porsche 936 - Martini Stripes 21/228 **£1.75**

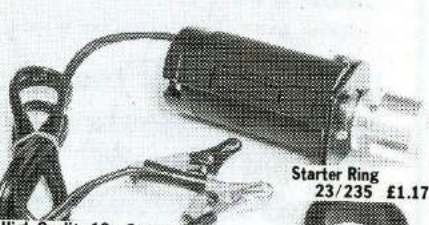
 <p>Shadow - GT Bodyshell Lexan 21/226 £8.52 ABS 21/227 £3.53</p>	<p>SPECIAL EXHAUST MANIFOLDS</p>  <p>OS 21F SR/C 14/103 £3.06 K & B 21 14/203 £3.83 OPS 35 23/218 £3.09</p>	 <p>Lotus 80F/1 Bodyshell Lexan 21/253 £8.52 ABS 21/254 £3.53</p>
 <p>Alloy Gear Carrier for Diff. 23/233 £2.85 Power Pod - Light weight Black 23/231 £10.12 Alloy Axle Block Black ea. 23/232 £2.67</p>	 <p>Quick Fill 125cc Fuel Tank 15/100 £4.80</p>	 <p>Epoxy Radio Plate 23/230 £8.14 Epoxy Narrow Chassis 23/229 £8.65</p>
 <p>Noise Reduction Kit for Standard Silencer 23/104 £3.09</p>	 <p>Power Silencer with adjustable Pipe 14/102 £15.92</p>	 <p>High Speed Main Bearing - suitable for OPS 3.5, K & B 21, ST21, OS21F, SR-C, Veco 19, HB and others 23/228 £8.54</p>
 <p>High Torque 800 rpm 12v Electric Drill 23/103 £12.78</p>	 <p>Fibre Disk 17/214 £2.41 ea. Brake Lining Metal 17/215 £0.43 ea.</p>	 <p>High Quality 12v. Starter 23/234 £30 Starter Ring 23/235 £1.17</p>

PB RACING PRODUCTS LTD. DOWNLEY ROAD, HAVANT, HANTS. 0705 471774

RADIO CONTROL